

# BOA Spot

## Quick Start Guide



## Notice

BOA Spot Quick Start Guide  
Document Number 405-00056-00

Copyright © 2021 Teledyne Imaging.  
All rights reserved.

All copyrights in this manual, and the hardware and software described in it, are the exclusive property of Teledyne Imaging and its licensors. Claim of copyright does not imply waiver of Teledyne Imaging or its licensors other rights in the work. See the following Notice of Proprietary Rights.

### NOTICE OF PROPRIETARY RIGHTS

This manual and the related hardware and software are confidential trade secrets and the property of Teledyne Imaging and its licensors. Use, examination, reproduction, copying, transfer and/or disclosure to others of all or any part of this manual and the related documentation are prohibited except with the express written consent of Teledyne Imaging.

The information in this document is subject to change without notice. Teledyne Imaging makes no representations or warranties with respect to the contents of this manual and specifically disclaims any implied warranties of merchantability or fitness for a particular purpose. Teledyne Imaging assumes no responsibility for errors or omissions in this document.

The Teledyne Imaging logo is a trademark of Teledyne Imaging. All other trademarks are the property of their respective owners.

Teledyne Digital Imaging US, Inc.  
**Information:** [TDI\\_Sales.ipd@teledyne.com](mailto:TDI_Sales.ipd@teledyne.com)  
**Support:** [TDI\\_Support.ipd@teledyne.com](mailto:TDI_Support.ipd@teledyne.com)  
**Web:** <http://www.teledynedalsa.com/visionsystems>

700 Technology Park Drive  
Billerica, MA, USA 01821

**Tel** 1.978.670.2002 **Fax** 1.978.670.2010

# Certifications

Declaration of Conformity	
Manufacturer	Teledyne Digital Imaging US, Inc. 700 Technology Park Drive Billerica MA 01867 USA
CE	We declare that this product has been tested to comply with the EC Directive for a class A digital device in accordance with EN55022/CISPR22.
FCC	We declare that this product has been tested and found to comply with the limits for a class A digital device, pursuant to Part 15 of the FCC rules. These limits are designed to provide reasonable protection against harmful interference in a residential installation.  This equipment generates, uses and can radiate radio frequency energy and may cause harmful interference to radio communication.
Other Certifications	
IP67	This product meets the requirements for industrial applications that require IP67 wash down protection - requires fitted sealing lens cover and sealing plugs on unused connectors.
CFR 21 Part 11	This product provides the tools needed for users to implement an auditing program that could be in compliance with CFR 21 Part 11. These tools include: <ul style="list-style-type: none"><li>• System or software backup and restore</li><li>• System software security (password login and access limits)</li><li>• Protection of system backup files from modification.</li><li>• Time stamp information on data output.</li><li>• Record of actions by users with time stamp information (models IDS &amp; IDE only).</li></ul>

## Handling Precautions

Care should always be exercised when handling and operating your BOA Spot Vision Sensor. Even though the system is encased within a rugged, industrial enclosure, incorrect use or handling can result in damage to your investment. To prevent this, we recommend following these precautions:

- Do not look directly into the LED ring light during operation! The light is extremely bright and may cause pain or damage your vision.
- Avoid “hot-plugging” cables and devices. Always shut the system down and remove power before connecting or disconnecting anything to it.
- Do not use in a Free-standing operation. Mount the BOA Spot properly to prevent it from falling accidentally. Mounting holes are provided on each side of the BOA Spot.
- Always use the BOA Spot within its recommended operating conditions. Refer to the complete specifications on page [24](#).
- Do not install BOA Spot in a location that will expose it to excessive heat, humidity, vibration, impact, corrosive substances, flammable substances, static electricity or Electro Static Discharge (ESD).
- Never expose the internal electronics by opening the enclosure.
- Do not attempt to modify the BOA Spot or open the case. This unit has no field-replaceable components (beyond replacing the Lens or Ring-light). Tampering with the unit will void the product warranty.

## Warranty

Teledyne Imaging warrants the BOA Spot Vision Sensor against defects in materials and workmanship for a period of twenty four (24) months from the date of delivery. Teledyne Imaging and its representatives expressly disclaim any and all other warranties.

Your sole remedy shall be repair or replacement of the BOA Spot Vision Sensor product and associated optional components, provided that the defective product is returned within the warranty period.

If you need to return the BOA Spot Vision Sensor, you must contact the Teledyne Imaging representative who sold you the product. Do not return your product to Teledyne Digital Imaging US without prior authorization.

Teledyne Imaging assumes no liability for damages resulting from the use of this manual.

# Table Of Contents

<b>Introduction</b>	Overview	6
	Inspection Capabilities	8
	Code Reading Considerations	9
	Components	11
	Lens, Cover & Light Options	12
	FOV and Distance	13
<b>Installation</b>	Connections	17
	Cable Pinouts	18
	Cable Configurations	19
	Camera Mounting Options	21
	Dimensional Drawings	22
<b>Specifications</b>	General Specifications	24
	Input Specifications	25
	Output Specifications	27
	PL-101 Specifications	29
	PL-101 Wiring Diagrams	30
	Serial Port Connection	31
<b>Software Setup</b>	How to Access BOA Spot	32
	Configure the PC	33
	Download Nexus and Install	36
	iDiscover Utility	38
	Launch Nexus and Connect	39
<b>Programming</b>	iInspect for BOA Spot	41
	Getting Started	42
	Upgrade BOA Spot Firmware	49
	iAssistant Utility	50
	iDisplay Utility	52
<b>Emulator Software</b>	Complementary Programs	54
	Emulator Configurator	55
<b>Troubleshooting</b>	Common Startup Issues	57

## BOA Spot Overview

BOA Spot is a fully integrated vision sensor in a compact “smart” camera format that has been specifically designed for industrial applications. Packaged complete with application software embedded, BOA Spot provides an easy-to-deploy automated inspection system for the factory floor. BOA Spot is compatible with Windows 7 and Windows 10. BOA Spot is not compatible with Windows XP.

BOA Spot vision sensors are rugged devices that can be integrated into existing production lines, machinery or moving equipment. They are supported by standard industrial M12 cordsets to further simplify and reduce implementation costs.

Rated for IP67 deployment when fitted with the M12 lens and lens cover, BOA Spot vision sensors can be mounted in wash down factory environments without the need for additional protective enclosures. The product is also available with a C-mount lens option for greater image quality, operating distance and lighting flexibility.

## Product Support

In addition to this Quick Start Guide, the following information is available:

1. On-line help: Fingertip help is available on every screen (panel) of the BOA Spot Software User Interface.
2. Additional manuals and documentation are included in the software download file.
3. Factory support is available by email at: [TDI\\_Support.ipd@teledyne.com](mailto:TDI_Support.ipd@teledyne.com).
4. Call, fax or email your local representative who sold you the product.

## BOA Spot Models

The BOA Spot is available in several different models or licensed tool set capabilities. Refer to page [8](#) for a list of tools by model.

- BVS-SP-0640M-IDS-x-y 640x480 mono sensor with “standard” reader tool set
- BVS-SP-1280M-IDS-x-y 1280x960 mono sensor with “standard” reader tool set
- BVS-SP-0640M-IDE-x-y 640x480 mono sensor with “expanded” reader tool set
- BVS-SP-1280M-IDE-x-y 1280x960 mono sensor with “expanded” reader tool set
- BVS-SP-0640M-SL-x-y 640x480 mono sensor with “standard” tool set
- BVS-SP-1280M-SL-x-y 1280x960 mono sensor with “standard” tool set
- BVS-SP-0640M-EL-x-y 640x480 mono sensor with “expanded” tool set
- BVS-SP-1280M-EL-x-y 1280x960 mono sensor with “expanded” tool set
- BVS-SP-0640C-SL -x-y 640x480 color sensor with “standard” tool set
- BVS-SP-0640C-EL-x-y 640x480 color sensor with “expanded” tool set
- BVS-SP-0640M-XL-x-y 640x480 mono sensor with combined IDE & EL (no DPM)
- BVS-SP-1280M-XL-x-y 1280x960 mono sensor with combined IDE & EL (no DPM)
- BVS-SP-0640M-XLE-x-y 640x480 mono sensor with combined IDE & EL & DPM
- BVS-SP-01280M-XLE-x-y 1280x960 mono sensor with combined IDE & EL & DPM
- BVS-SP-0640C-XL-x-y 640x480 color sensor with combined IDE & EL (no DPM)
- BVS-SP-0640C-XLE-x-y 1280x960 color sensor with combined IDE & EL & DPM

### Upgrading the BOA Spot:

The BOA Spot can be field upgraded. The upgrades can be purchased through our local reseller and will require sending the **serial number** and **MAC ID** of the device, which are displayed on the web server home page (page [36](#)). The upgrade license is entered in the Upgrade field at the bottom of the BOA Spot web server home page.

The IDS can be upgraded to the IDE. The SL can be upgraded to the EL. The EL can be upgraded to the XL. The XL can be upgraded to the XLE.

---

### System Upgrades:

If your camera supports model upgrades, enter a valid license in the field below to Upgrade.

Enter Upgrade Key:

---

## BOA Spot Inspection Capabilities

This table shows the available tools by model. The on-line help has more information.

Tool		Models	Description
Barcode		IDS,IDE,XL	Decode linear codes, Pharmacode, databar, postal, & more.
2D Matrix		IDS,IDE,XL	Decode Data matrix, QR Code, PDF417, MicroQR, & more.
OCR		IDE,XL	Read printed, stamped, or etched characters.
OCV		IDE, XL	Measure quality of characters.
Preprocess		IDS,IDE,XL	Add filtering to accentuate image features.
Verify		IDE,XL	Verify features such as labels or logos. Train on a series of good samples to learn acceptable variation.
Match		IDE,XL, SL,EL	Train and match features for inspection or tool alignment. Supports 360° orientation.
Count		All models	Count features, or locate a feature.
Edge Count		IDE,XL, SL,EL	Find or count edge transitions and positions.
Point		All models	Find a single edge point position. Assign points as “anchors” to align other tools.
Intensity		SL,EL,XL	Calculate statistics or detect presence & absence.
Caliper		SL,EL,XL	Measure distances. Supports irregular shapes.
Distance		EL,XL	Measure distance between 2 edges.
Rake		EL,XL	Measure multiple distances and average between 2 edges.
Angle		EL,XL	Measure an angle between 2 edges.
Arc		EL,XL	Measure radius of a curve.
Circle		EL,XL	Measure diameter of a circle.
Concentric		EL,XL	Measure on-center or wall thickness.
Contour		EL,XL	Find flashing or burring.
Tip		EL,XL	Find and extremity or “tip” of an object.
Graphics		EL,XL,IDE	Add text or draw shapes, to label or highlight tool results or features in the image.
Color Meter		Color only	Identify colors, or measure percentage of colors.



## Code Reading Considerations

BOA Spot offers fast decoding of 1D and 2D codes printed or directly marked on a variety of surfaces, including paper, plastic and metal. The decoder is robust and able to read poorly printed, worn or environmentally degraded codes in any orientation.

Guidelines for reliable code reading are as follows:

### 1D Codes

- Minimum distance between bars = 1.5 pixels (2.5 pixels for low contrast)
- Minimum bar width = 1.5 pixels (2.5 pixels for low contrast)

### 2D Codes

- Minimum cell size = 2 x 2 pixels
- Minimum dot diameter = 2 pixels

### All Codes

- Non-DPM = Maximum ROI size = 1280 x 960
- DPM = Maximum ROI area = 614,400 pixels (i.e. 1280 x 480, 1024 x 600, 960 x 640, 800 x 768 and anything smaller, such as 640 x 480)
- Use “Invert” preprocessor to decode light-on-dark barcodes
- With the exception of “low contrast”, the control parameters described on the next page are mutually exclusive. Only one can be enabled at a time.

General deployment guidelines:

- Choose a lens that satisfies the FOV and minimum bar/module size.
- Adjust working distance to maximize the code FOV wherever possible.
- BOA Spot with integrated light is a good choice for high contrast codes printed on non-reflective surfaces.
- BOA Spot with external dark field light is better for dot peen codes.
- BOA Spot with external diffuse off-axis light is better for curved or highly reflective surfaces.
- Increase light and reduce shutter time to stop motion for fast moving applications.

## Compensating for Code Variability

The variability between surface type and printing method can result in significant changes in code appearance from part to part. The BOA Spot includes image filters and control parameters to enhance readability for poor print quality or direct part marking (DPM). The Advanced DPM license includes advanced algorithms specifically designed for challenging DPM applications.

Control Parameter	License	Description
Low Contrast	“Standard” level IDS, IDE, XL	Enables decoding of low contrast 1D codes (D-on-L or L-on-D) with a minimum module size of 2.5 pixels.
Enhance Contrast	“Standard” level IDS, IDE, XL	Enables contrast enhancement preprocessor to improve readability of 1D or 2D.
1D Security Level	“Standard” level IDS, IDE, XL	Helps improve 1D decoding when print quality is poor or module size is marginal.
Basic Etch	“Standard” level IDS, IDE, XL	Enables decoding of basic laser or chemical etch DPM codes.
Basic Dots	“Standard” level IDS, IDE, XL	Enables decoding of basic dots DPM codes, including inkjet marks.
Basic Inkjet	“Standard” level IDS, IDE, XL	Enables decoding of poor quality inkjet DPM codes.
Basic Perspective	“Standard” level IDS, IDE, XL	Enabled decoding of good quality, centered codes with severe perspective distortion.
Dot peen D-on-L	“Advanced DPM” IDE, XLE	Enables robust algorithm for decoding dark on light dot peened codes.
Dot peen L-on-D	“Advanced DPM” IDE, XLE	Enables robust algorithm for decoding light on dark dot peened codes.
Laser & Chemical Etch	“Advanced DPM” IDE, XLE	Enables robust algorithm for decoding laser and chemically etched codes.
DPM Timeout	“Advanced DPM” IDE, XLE	Total time in ms that the advanced algorithm is allowed to run. A value “0” indicates no timeout.

## BOA Spot Components

BOA Spot vision sensors are shipped with the components listed below. Take a few moments to verify that everything has arrived in good condition. If your product has been visibly damaged during shipment or is missing parts, please contact your Teledyne Imaging representative immediately.

Standard components (ship with every BOA Spot Vision Sensor):

Component	Description
<u>BOA Spot Sensor</u> BVS-SP-0640M-LL-TFF-C BVS-SP-1280M-LL-TFF-C BVS-SP-0640C-LL-TFF-C	Fully integrated with 640x480 monochrome or color sensor, or 1280x960 monochrome sensor, lens, processing engine, embedded software, communications and light control. (LL= feature level: IDS, IDE, SL, EL, XL, XLE); (T = lens type: M= M12, C=C Mount); (FF* = focal length in mm: 06, 08, 12, 16); (C= Ring-Light Color: R=red 625nm, B=blue 475nm, W=white, X=none*)
Mounting Screw Kit	M4 screws for mounting the BOA Spot (Qty 4)

\* Lens and ring-light are only specified for the M12 version, not available with C Mount lens.

Optional components (sold separately):

Component	Description
<u>Cables</u> A-BVS-E8S-X A-BVS2-IO12S-X	M12-RJ45 Ethernet cordset (X= length: 5=5 m, 10=10 m) M12 single-ended IO cordset (X= length: 5=5 m, 10=10 m)
BVS-PL-101 A-BVS-PL101S-X	Panel Link breakout module. Provides convenient panel access to BOA Spot I/O and serial port M12 IO cordset to PL-101 (X= length: 5=5 m, 10=10 m)
BVS-PL-100	Panel Link breakout module for Passive Power on Ethernet
BVS-PL-200-E	Panel Link Ethernet Switch for Passive Power on Ethernet
A-BVS-SP-LCG-45	Lens Cover for C Mount lens option. Required for IP67 compliance. (45 mm internal lens length)
A-BVS-M12-P	M12 plug for IP67 compliance
A-BVS-SP-M12-KIT	M12 lens kit (includes 6, 8, 12, 16 mm lenses)
Lights	Various Lighting options available from Teledyne Imaging
Filters	Various C-Mount filters available from Teledyne Imaging

## Lens, Cover, and Light Options

### M12 Lens

The BOA Spot vision sensor can be ordered with an M12 lens in several focal lengths (6, 8, 12, 16 mm). The M12 option comes with a special IP67 cover, that allows you to change focus without removing the cover.

The M12 Lens and cover also supports an optional LED ring-light that is mounted inside the cover. The ring-light is available in White, Red (625 nm), or Blue (475 nm) and specified at time of order.

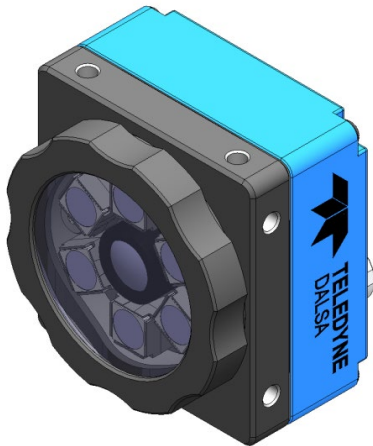

M12 Lens, Cover, and LED ring



M12 cover rotates to adjust focus

### C-Mount Lens

The BOA Spot Vision Sensor can be ordered with support for a C-Mount lens. Lenses are sold separately.

There is an optional IP67 Lens cover that may be ordered separately.

There is no internal light option with the C-Mount lens.

Optional filters can be ordered separately for use with the C-Mount lens.



C-Mount Lens  
shown with Optional Cover

## Field Of View (FOV) and Reading Distances

### 6 mm M12 Lens

This table shows the field of view (FOV) widths of the 6 mm M12 lens at various working distances for the M640 & M1280 model sensors. The minimum Working Distance or Focal distance with this lens is 38 mm.

Working Distance (mm)	Approximate FOV (mm)		Image Pixel size (um)	2D min cell (mil)	1D min bar (mil)
	640 Model	1280 Model			
38	17 x 13	33 x 25	26.1	2.1	1.5
150	65 x 48	129 x 97	100.9	7.9	6.0
300	129 x 96	257 x 193	201.0	15.8	11.9
600	257 x 193	513 x 385	401.1	31.6	23.7
1000	428 x 321	855 x 641	668.0	52.6	39.5

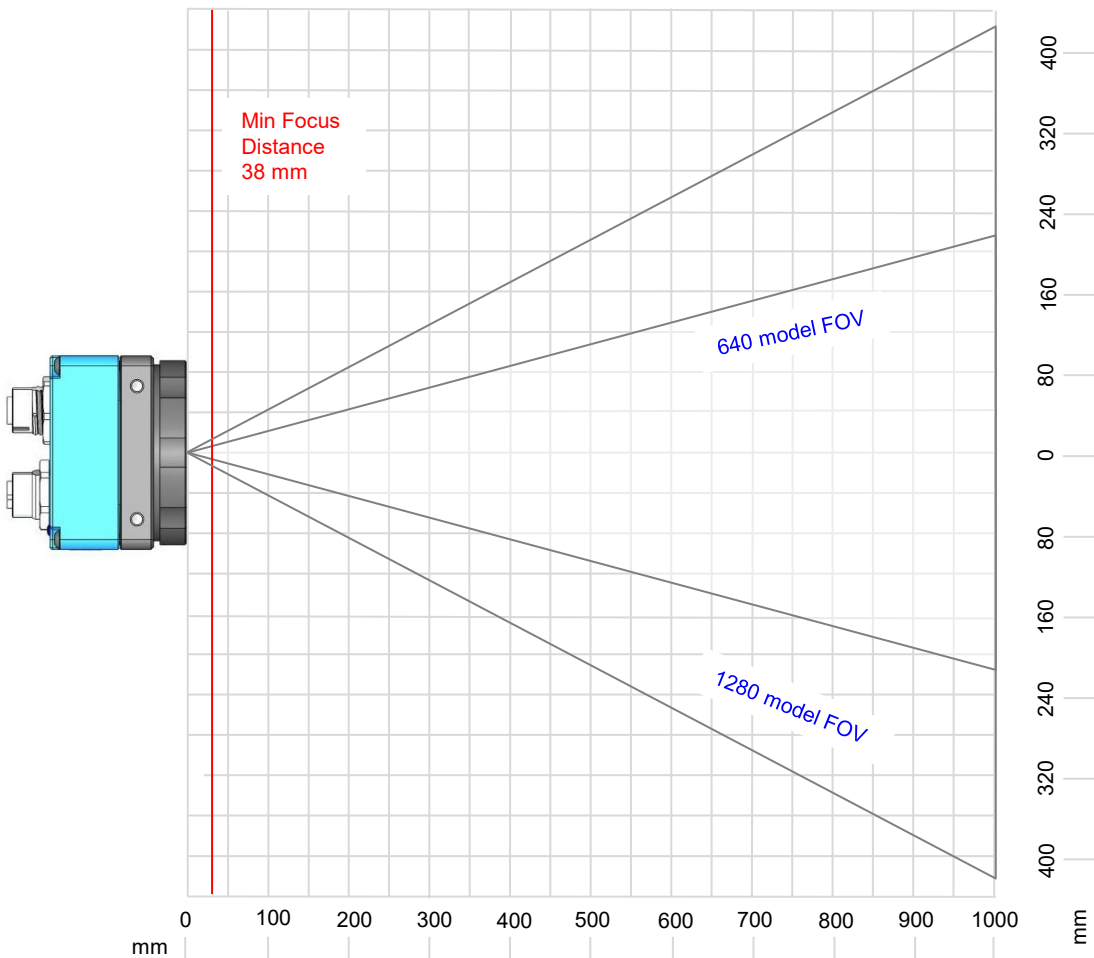

## 8 mm M12 Lens

The following table shows the field of view (FOV) widths of the 8 mm M12 lens at various working distances for the M640 & M1280 model sensors. The minimum Working Distance or Focal distance with this lens is 38 mm.

Working Distance (mm)	Approximate FOV (mm)		Image Pixel size (um)	2D min cell (mil)	1D min bar (mil)
	640 Model	1280 Model			
38	11 x 8	22 x 16	17.1	1.3	1.0
150	46 x 35	92 x 69	72.2	5.7	4.3
300	93 x 70	187 x 140	146.0	11.5	8.6
600	188 x 141	376 x 282	293.6	23.1	17.3
1000	314 x 235	628 x 471	490.4	38.6	29.0

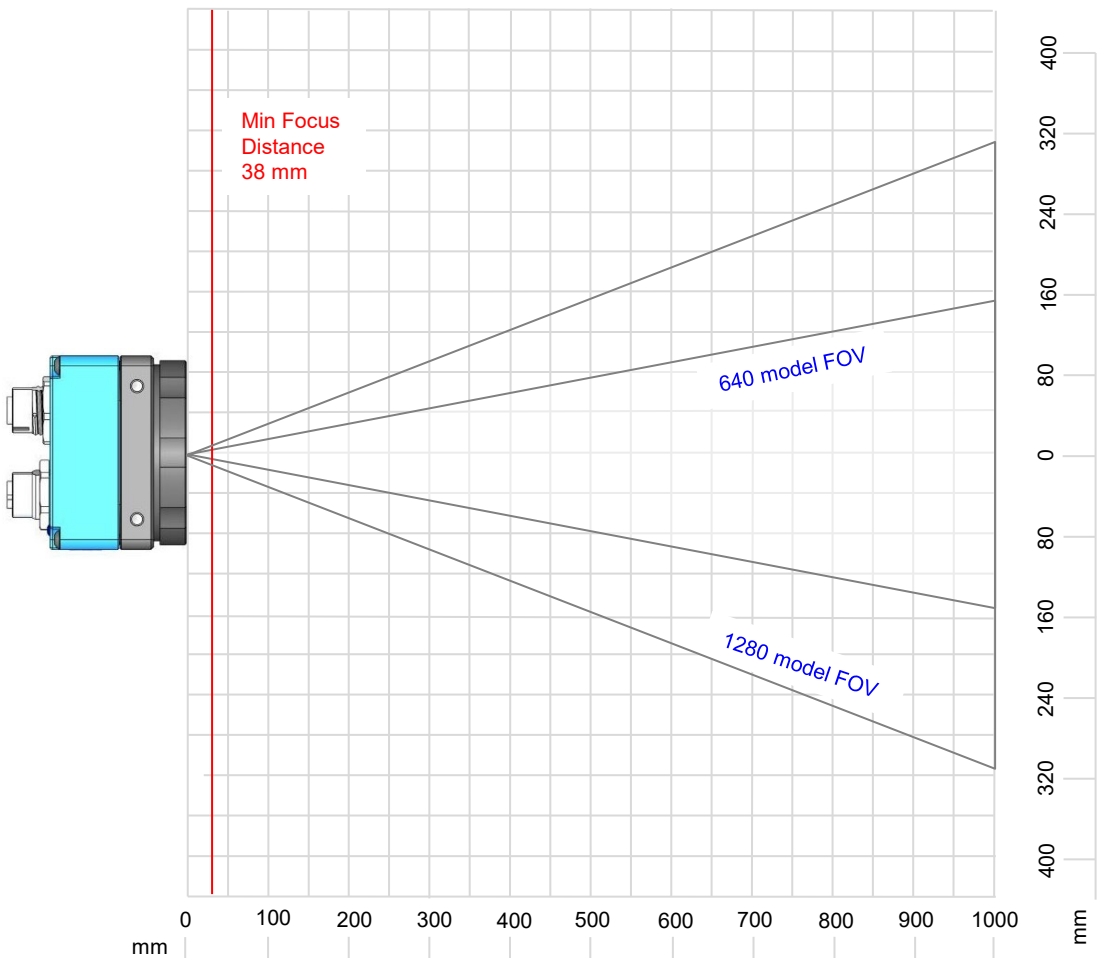

## 12 mm M12 Lens

The following table shows the field of view (FOV) widths of the 12 mm M12 lens at various working distances for the M640 & M1280 model sensors. The minimum Working Distance or Focal distance with this lens is 64 mm.

Working Distance (mm)	Approximate FOV (mm)		Image Pixel size (um)	2D min cell (mil)	1D min bar (mil)
	640 Model	1280 Model			
64	11 x 8	21 x 16	16.5	1.3	1.0
150	28 x 21	56 x 42	44.1	3.5	2.6
300	59 x 44	118 x 88	92.2	7.3	5.4
600	121 x 90	241 x 181	188.4	14.8	11.1
1000	203 x 152	405 x 304	316.7	24.9	18.7

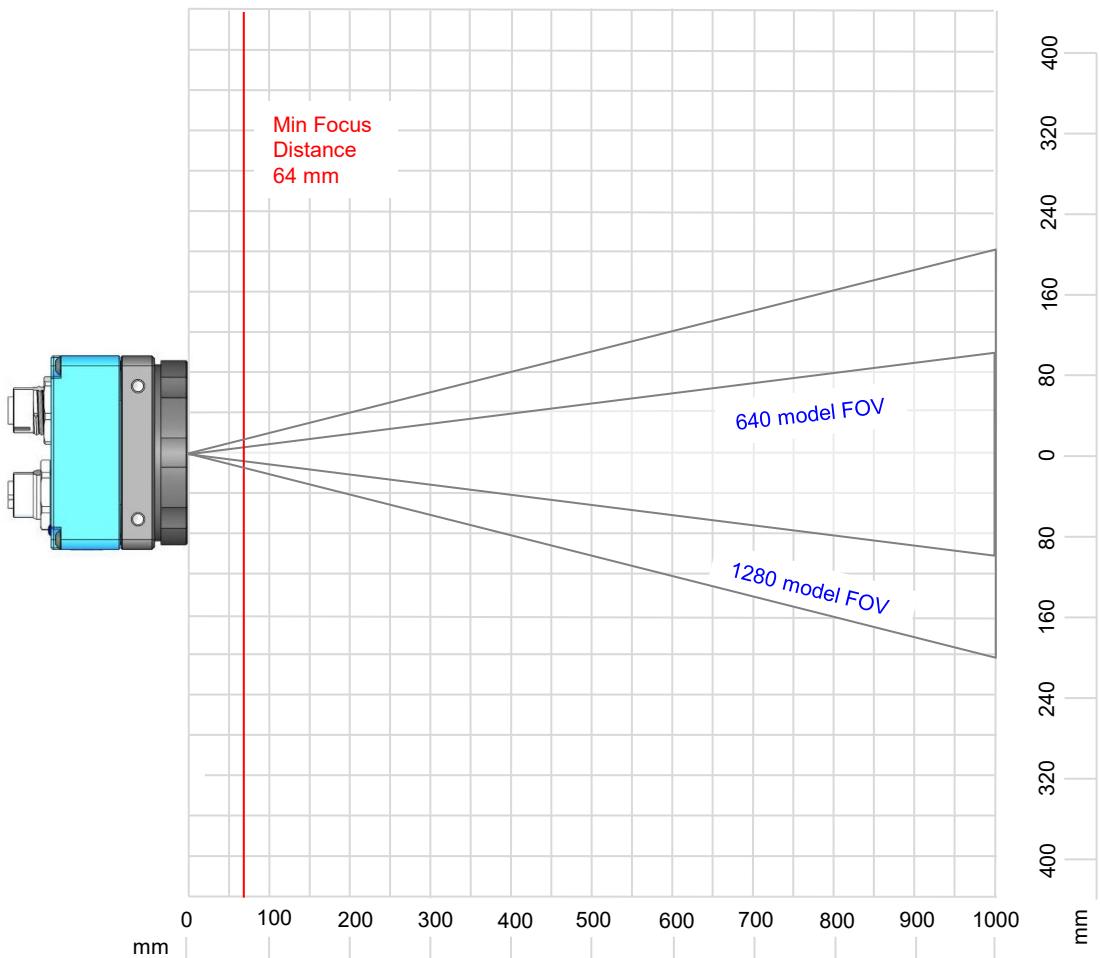

## 16 mm M12 Lens

The following table shows the field of view (FOV) widths of the 16 mm M12 lens at various working distances for the M640 & M1280 model sensors. The minimum Working Distance or Focal distance with this lens is 127 mm.

Working Distance (mm)	Approximate FOV (mm)		Image Pixel size (um)	2D min cell (mil)	1D min bar (mil)
	640 Model	1280 model			
127	17 x 13	34 x 25	26.4	2.1	1.6
150	20 x 15	41 x 30	31.7	2.5	1.9
300	43 x 32	85 x 64	66.5	5.2	3.9
600	87 x 65	174 x 131	136.0	10.7	8.0
1000	146 x 110	293 x 220	228.7	18.0	13.5

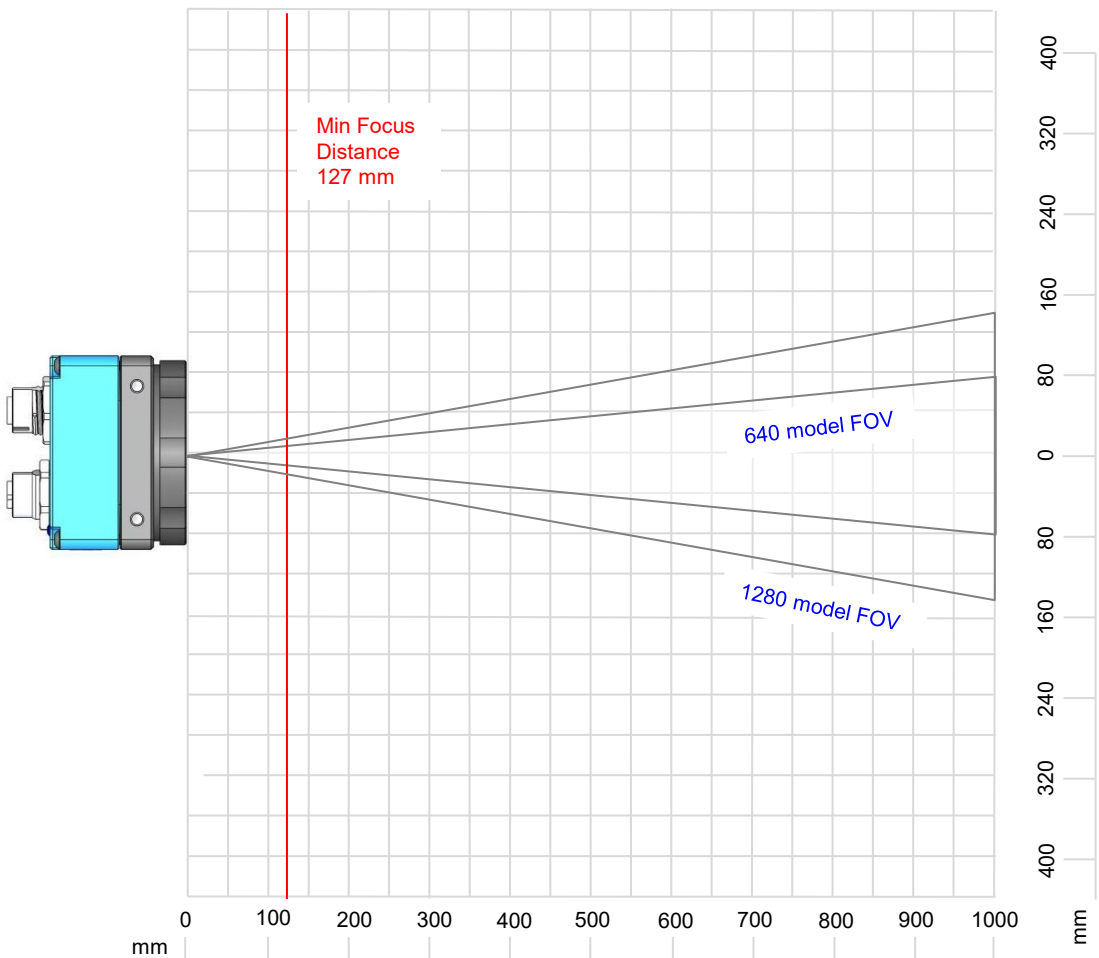



## Connecting the BOA Spot Vision Sensor

This section details how to connect the BOA Spot Vision Sensor with its associated components and factory environment.

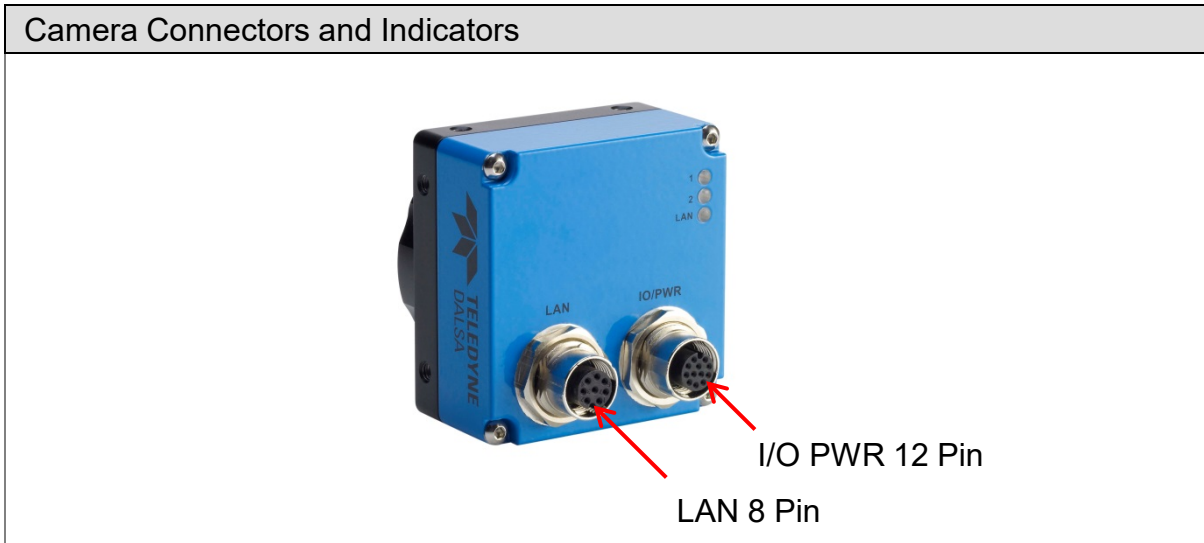

Connectors	Definitions
LAN	10/100 BaseT Ethernet connection. Provides the primary interface for configuring the sensor, developing the application and monitoring results. <b>Note:</b> The BOA Spot can be powered from the Ethernet cable directly (Passive Power over Ethernet or PPOE).
I/O PWR	Provides access to the sensor I/O – 3 IN, 3 OUT, RS-232. Also provides PWR input (24V). <b>Note:</b> The power is common to both connectors.
LED Indicators	Definitions
1	<b>Blue Solid</b> = Sensor booted, not configured (no Solution file) <b>Green Solid</b> = Solution loaded, ready to run <b>Green blink</b> = Solution loaded & running, acquisition in process <b>Red</b> = Sensor Fault
2	<b>Blue blink</b> = Booting (should stop after 20 seconds) <b>Green</b> = Inspection Pass (runtime decision result) <b>Blue</b> = Inspection Recycle (runtime decision result) <b>Red</b> = Inspection Fail (runtime decision result)
LAN	<b>Blue</b> = Warm reset or reboot <b>Red/Green/Yellow</b> = Network activity

**NOTE:** The BOA Spot does not support the IEEE 802.3af standard Power over Ethernet (PoE) and should not be directly connected to a PoE supported router.

## Cable Pinouts

The BOA Spot Vision Sensor is compatible with M12 factory cordsets as show below:

### LAN Connector Pinout

M12	Name	RJ45
1	PWR *	5
2	NC	7
3	GND *	8
4	TDX-	2
5	RDX+	3
6	TDX+	1
7	NC	4
8	RDX-	6

**NOTE:** the BOA Spot LAN connection is different than specified in the ProfiNet interconnection technology guide.

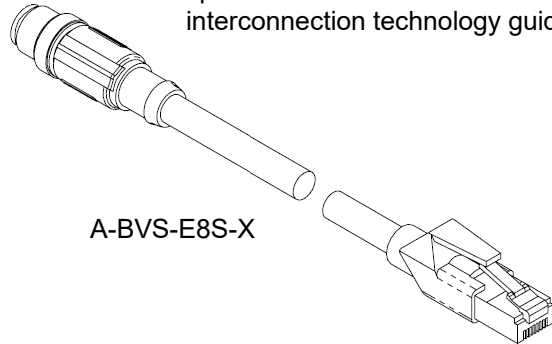

A-BVS-E8S-X

\* For Passive Power over Ethernet

### I/O-PWR Connector Pinout

M12	Name	Wire
1	PWR	 Brown
2	GND	 Blue
3	OUT2	 White
4	OUT CMN	 Green
5	IN0 / TRIG	 Pink
6	IN2	 Yellow
7	IN CMN	 Black
8	RS232 TX	 Gray
9	RS 232 RX	 Red
10	OUT 1	 Purple
11	OUT 0	 Gray/Pink
12	IN 1	 Red/Blue

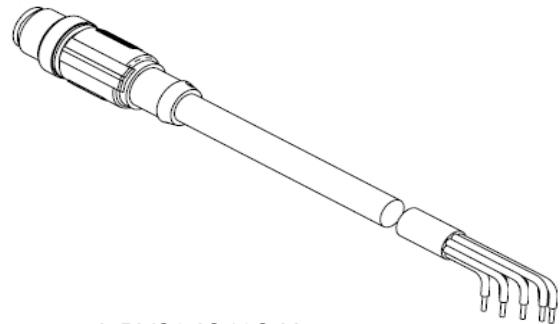

A-BVS2-IO12S-X

## Cable Configurations

The BOA Spot Vision Sensor offers flexible cabling to suit a number of application configurations:

1. For typical applications, both the Ethernet and I/O-PWR cables are connected to provide flexibility between the sensor and the control environment. In this configuration, power is usually supplied by the I/O-PWR cable. **Note: Power is common to both BOA Spot connectors.** Either or both cables can supply power provided they come from the same power source. Do not connect different power sources to the BOA Spot connectors. **Note: The PL-101 is for this configuration.**
2. For single cable applications that do not require I/O, the Ethernet cable can be used to supply power (referred to as “Passive Power over Ethernet” or PPOE) and communications between the sensor and the control environment. Power is supplied by connecting a 24 Volt DC power source to conductors (PWR and GND) on the Ethernet RJ45 connector. In this configuration, the sensor I/O is unavailable. **Note: The PL-100 and PL-200-E modules supply Passive Power on the Ethernet connection.**
3. For single cable applications that do not require an Ethernet connection at runtime, the I/O-PWR cable provides limited communications and power between the sensor and the control environment. **Note: The PL-101 is for this configuration. An Ethernet connection is still required for setup.**

## Panel Link Modules

The PL-101 and PL-100 are optional modules that provide a safe and convenient way to interface with BOA Spot. The PL-101 provides an isolation barrier between the factory and the sensor I/O (differential isolation) and allows convenient panel wiring. The PL-100 provides convenient Passive Power on the Ethernet connector.

**PL-101**  
A-BVS2-PL-101

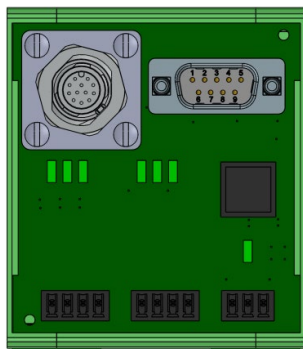

**PL-100**  
A-BVS-PL-100

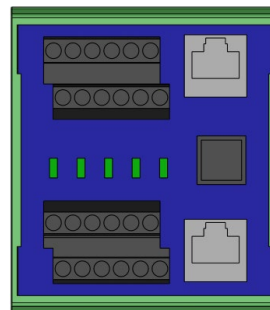

**NOTE:** The BOA Spot does not support the IEEE 802.3af standard Power over Ethernet (PoE) and should not be directly connected to a PoE supported router.

## Ethernet and I/O Setup

1. Connect the M12-8 male end of the Ethernet cordset (A-BVS-E8S-X) to the M12-8 female connector labeled “LAN” on the sensor.
2. Connect the RJ45 end of the Ethernet cordset to the RJ45 on the client PC, PLC or factory LAN (PC is only required for setup)
3. Connect sensor PWR, GND, trigger and I/O from the control panel to the breakout screw terminals on the PL-101.
4. Connect one end of the M12-12 male IO-PWR cordset (A-BVS-PL101S-X) to the M12-12 female connector on the sensor labeled “IO/PWR”. Connect the other end of the cable to the M12-12 female connector on the PL-101.

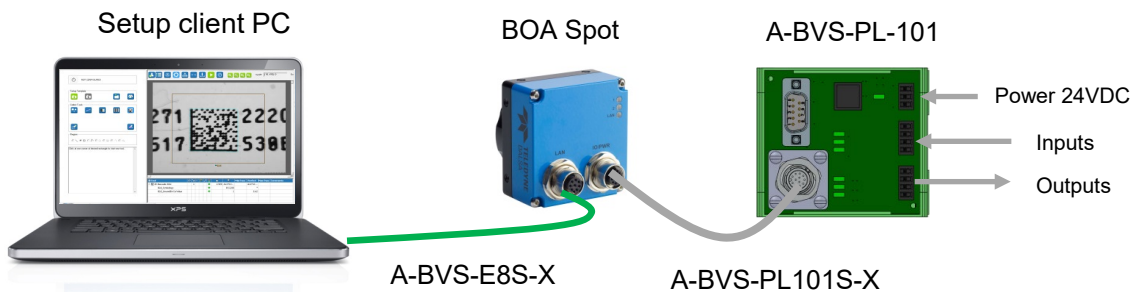

## Ethernet Only Setup

1. Connect the M12-8 male end of the Ethernet cordset (A-BVS-E8S-X) to the M12-8 female connector labeled “LAN” on the sensor.
2. Connect the RJ45 end of the Ethernet cordset to the RJ45 connector labeled “CAM LAN” on the Panel Link breakout module (A-BVS-PL-100 or A-BVS-PL-200-E)
3. Connect the RJ45 labeled “LAN” on the breakout module to the controlling PC, PLC or the factory LAN
4. Connect sensor PWR and GND to the breakout screw terminals labeled “PWR”.
5. Optionally, a IO-PWR Cordset (A-BVS-PL101S-X) can be connected to the PL-100 to use 2 inputs and outputs.

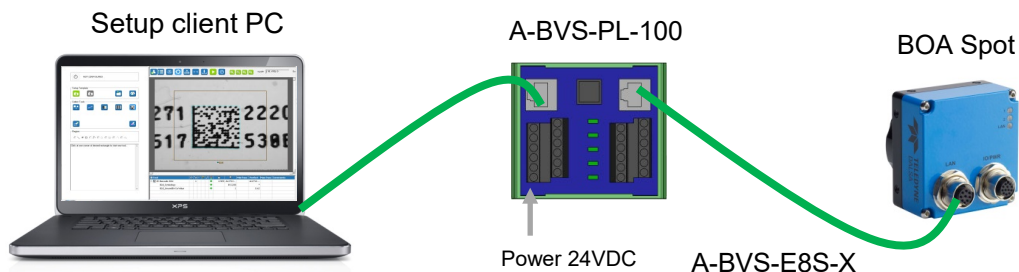

**Note:** The trigger button on the PL-100 does not function in this configuration.

## Mounting Options

The BOA Spot Vision Sensor provides M4 holes on the sides of the sensor for convenient mounting as shown in the following illustrations.

Surface Mount

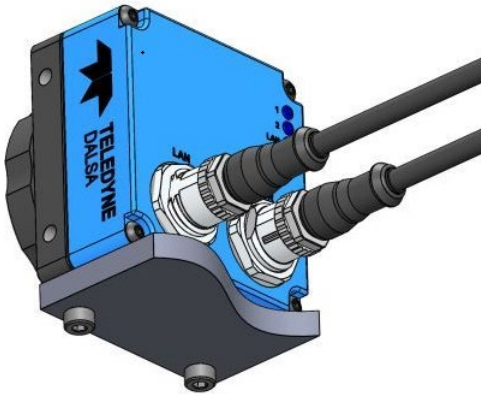

Thru Fit Mount

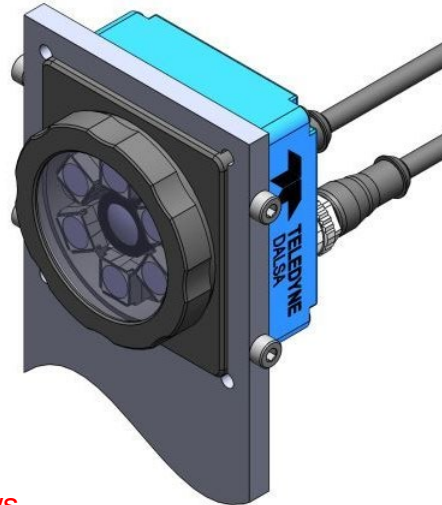

We recommend using more than two screws in high vibration environments

# BOA Spot Mechanical Dimensions

Note: All dimensions in mm

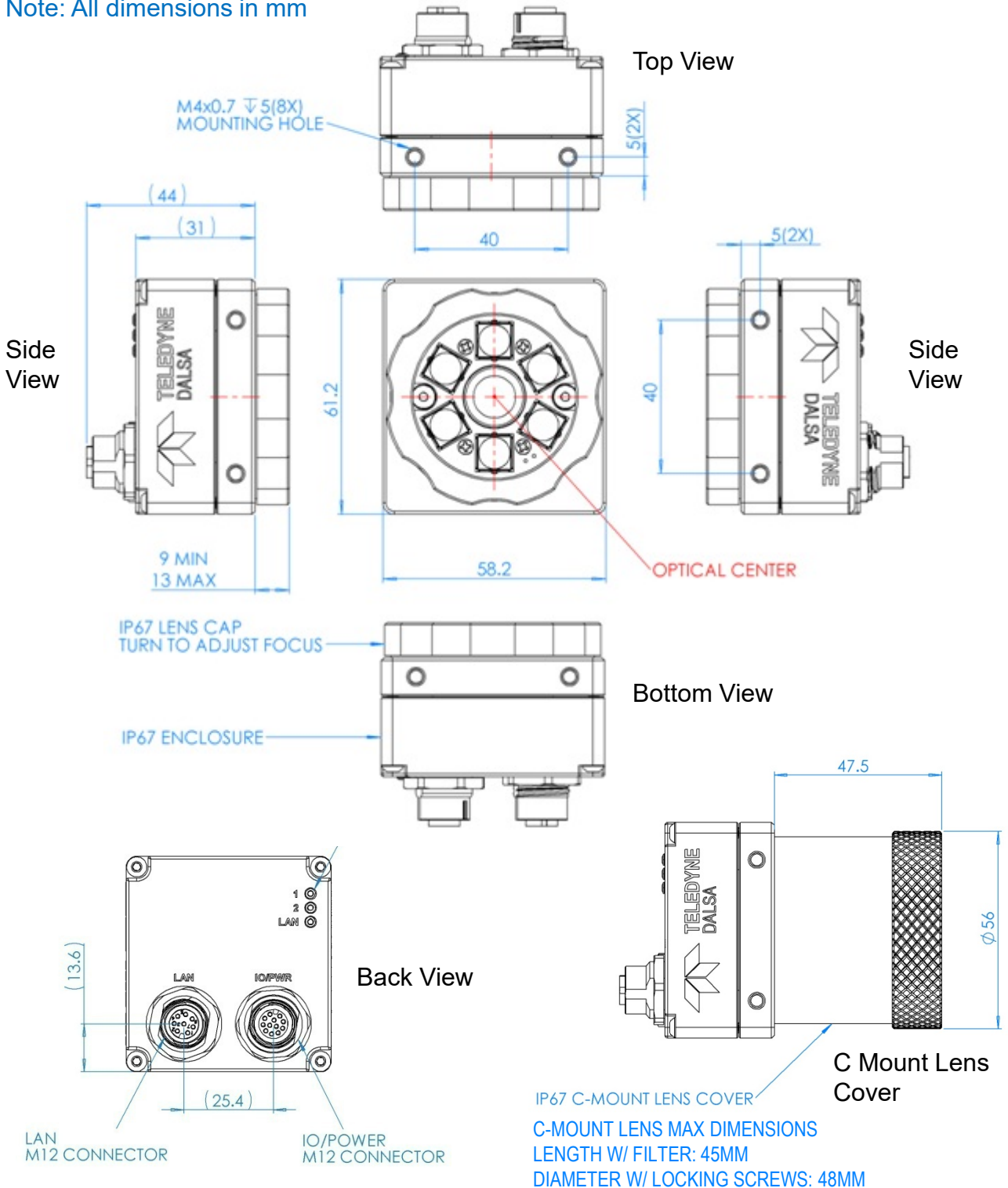

# Panel Link Mechanical Dimensions

Note: All dimensions in mm

PL-101 Top View

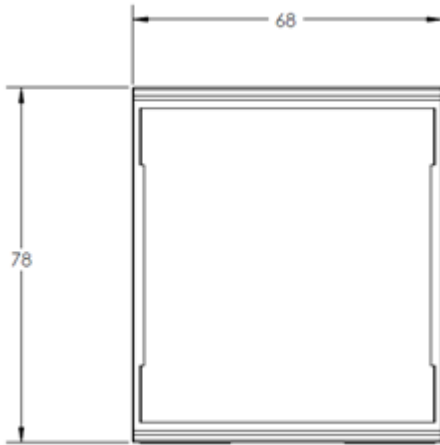

PL-101 Side View

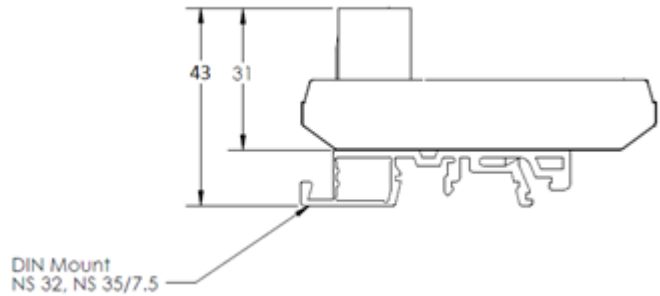

PL-100 Top View

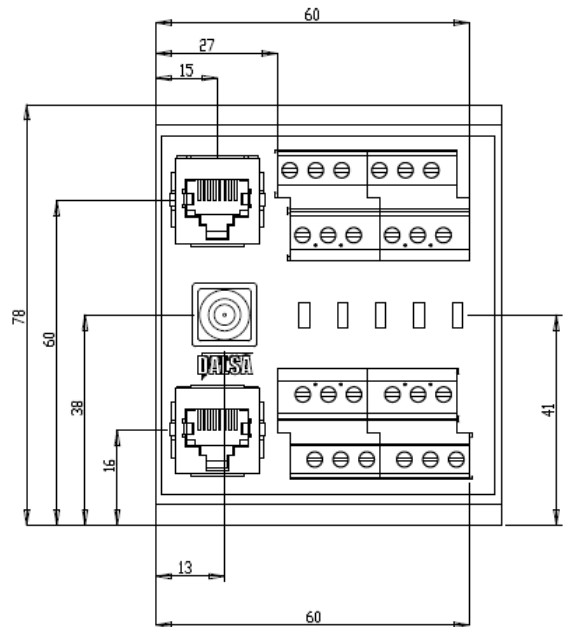

PL-100 Side View

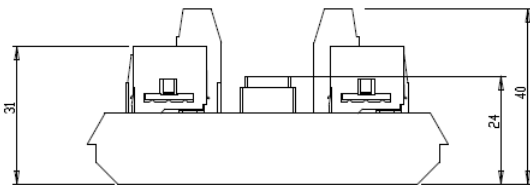

## General Specifications

This following table lists the specifications of the BOA Spot Vision Sensor:

Specification		Definition
Memory	Storage	256MB Storage; 256MB Program
Image	Sensor	1/3" CMOS; 3.75 $\mu$ m pixel size, Global Shutter
	Resolution	640x480 Mono or Color, 1280x960 Mono only
	Type	Progressive Scan
	Exposure	50 us to 51.10 ms
	Acquisition	full-frame integration, 640x480 45 f/s, 1280x960 30 f/s Maximum achievable speed is application dependent
	Lens	M12 or C Mount (factory configured)
I/O	Trigger	1 opto-isolated hardware trigger input  Software trigger via Ethernet or internal timer
	Inputs	2 General purpose opto-isolated.
	Outputs	3 General purpose opto-isolated
	Strobe	1 output may be used to sync an external light source
	Status	Network + 2 application assigned LEDs
	Network	Ethernet
Serial	RS232	1 Port on I/O connector
Power	24 V	on I/O or Ethernet connectors (not IEEE 802.3af PoE compliant)
	Device	(BOA Spot) 5.64 Watts; 235 mA maximum @ 24 V
	Lamp	(LED Ring-Light) 9.74 Watts; 406 mA maximum @ 24 V
Mechanical	Material	Machined Aluminum with anodize/paint finish
	Mounting	8 x M4
	Size	58.2 mm x 61.2 mm x 53 mm with M12 lens cover, 58.2 mm x 61.2 mm x 91.5 mm with C Mount lens cover
	Weight	170.1 grams (6 oz) C-mount without lens or lens cover, 235.3 grams (8.3 oz) with M12 lens and cover
Environment	Temp	-10°C (14°F) to 50°C (122°F) Operating (-60°C to 80°C) Storage
	Protection	IP67 with cables attached
	Shock	70 G
Certification		FCC Class A and EU CE



## Input Specifications

The BOA Spot Vision Sensor provides three (3) dedicated opto-isolated, polarity independent inputs. One of the inputs provides the acquisition Trigger function, while the other two are general purpose.

Specification		Definition
Voltage	ON	11-30 V
	OFF	0-3 V (12 V nominal threshold)
Current	ON	8.0 mA typical (24 V applied)
Protection	Resistance	3.0 K Ohms
	Isolation	4000 V RMS
Common pin	Input	PWR or GND
Switch Time	ON	20 Microseconds
	OFF	10 Microseconds
Latency	Trigger	62 Microseconds from trigger input to start of acquisition

The active polarity of each input is configured in the iNspec for BOA Spot application, as detailed on page [45](#). The sensor includes a noise filter on the input which is also configurable.

To connect with an NPN source, connect the sensor's input (pin 5, 6 or 12) to the NPN source output and the sensor's common input (pin 7) to PWR. When the source output turns ON, the sensor's input will be pulled down turning the opto-coupler ON.

To connect with a PNP source, connect the sensor's input (pin 5, 6 or 12) to the PNP source output and the sensor's common input (pin 7) to GND. When the source output turns ON, the sensor's input will be pulled up turning the opto-coupler ON.

### Input Diagram

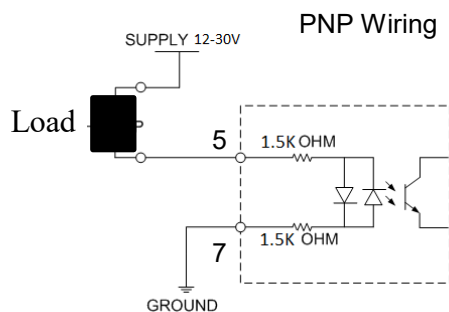
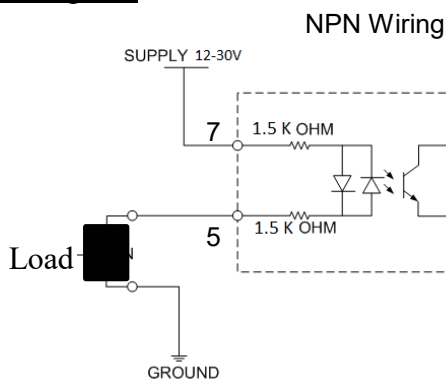

## Job Switching Using Inputs

BOA Spot can store up to 32 Solutions (job files) that can be loaded on demand via a hardware switch. The switch uses the general purpose GPI1 & GPI2 inputs. A PLC, or other hardware controlling device, sets a HIGH signal on the “job change” line (GPI1) and sends a series of pulses on the “job select” line (GPI2) equal to the solution #. i.e. solution 12 = 12 pulses.

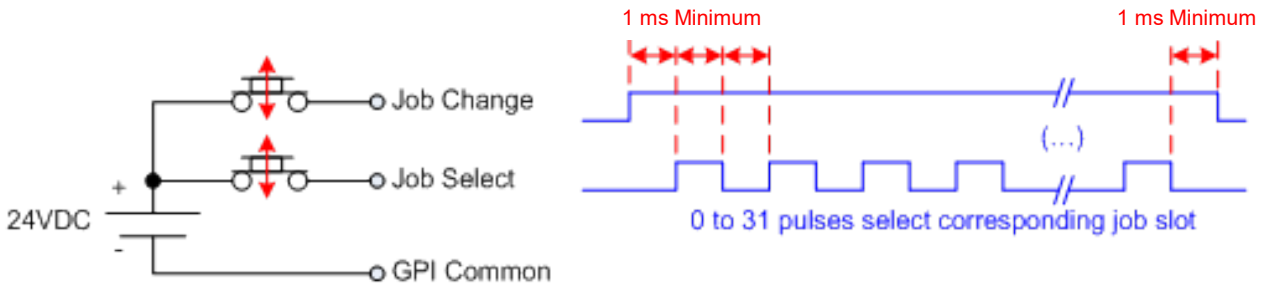

The pulse train requires a 1 millisecond (1 ms) setup and hold time between any edge transition. When a solution switch is detected, BOA Spot will abort the current inspection (if running) and switch immediately.

To use the BOA Spot inputs for job switching, select the “Job Change” and “Job Select” functions in the Input control setup panel as shown.

Input	Control	Debounce (us)	Triggers Per Image	Value
Trigger (GPIO)	Active High	200	1	0
GPI1	Job Change			0
GPI2	Job Select			0

**Note:** OS 151209 or later, Hardware version 21414 or later, and Firmware version 1997 or later is required to support the “hardware switch” operation described on this page.

**Note:** Job switching is also supported through the software user interface and scripting.

## Output Specifications

The BOA Spot Vision Sensor provides three (3) dedicated opto-isolated, solid state relay outputs. One may be used as “strobe” pulse output for an external light source. Or all three can be used as decision or general purpose outputs.

Specification		Definition
Voltage (Vin)	Load	30 V maximum
Current	GPO[0:2]	160 mA max @ 20°C (drives to OCMN when active)
Protection	Fuse	PTC fuses to 160 mA at 20°C or 100 mA at 70°C
Common pin	Out	PWR or GND
Switch Time	ON	150 Microseconds typical
	OFF	50 Microseconds typical

The active polarity of each output is configured in iNspec for BOA Spot application as detailed on page [46](#).

To connect with an PNP input source, connect the sensor’s output (pin 3, 10 or 11) to the PNP source input and the sensor’s common output (pin 4) to GND. When the sensor’s output turns ON, the opto switch closes and OUTX = 0 (current flows through load).

To connect with an NPN input source, connect the sensor’s output (pin 3, 10 or 11) to the NPN source input and the sensor’s common output (pin 4) to PWR. When the sensor’s output turns ON, the opto switch closes and OUTX = output common.

### Output Diagram

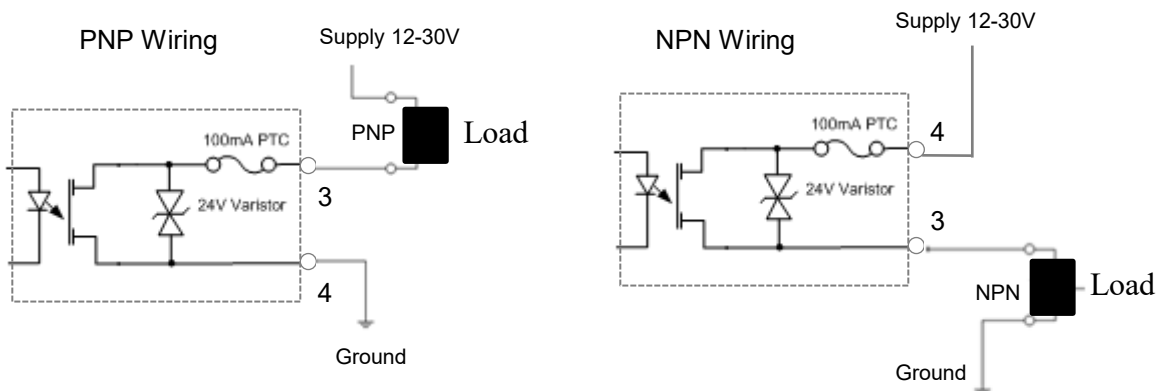

## Output Considerations

A hardware output is a signal with a fixed programmed pulse duration and fixed programmed offset relative to the incoming Trigger signal. Set one output to PASS and another to FAIL. If processing is not complete when the output decision is scheduled, a FAIL output will result. This method guarantees a PASS or FAIL output at a predictable offset for every trigger. (called a “deterministic” output).

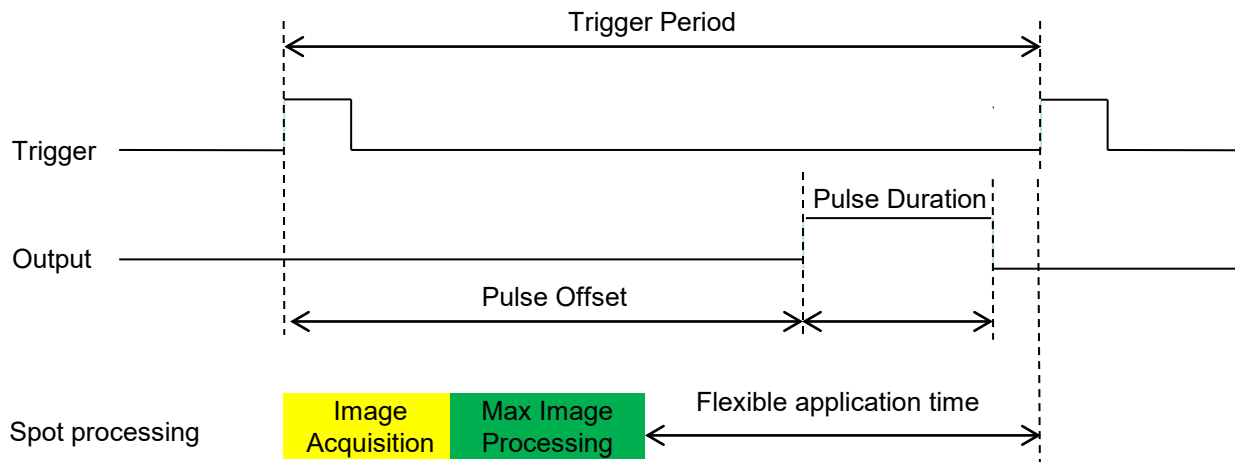

A software output is a signal with a fixed pulse output duration but has a variable offset relative to the Trigger signal. The variability depends on the total processing time per image. Set one output to PASS and another to FAIL. Software will determine which output to pulse at the end of processing. This method guarantees a PASS or FAIL output for every trigger, but does not guarantee timing.

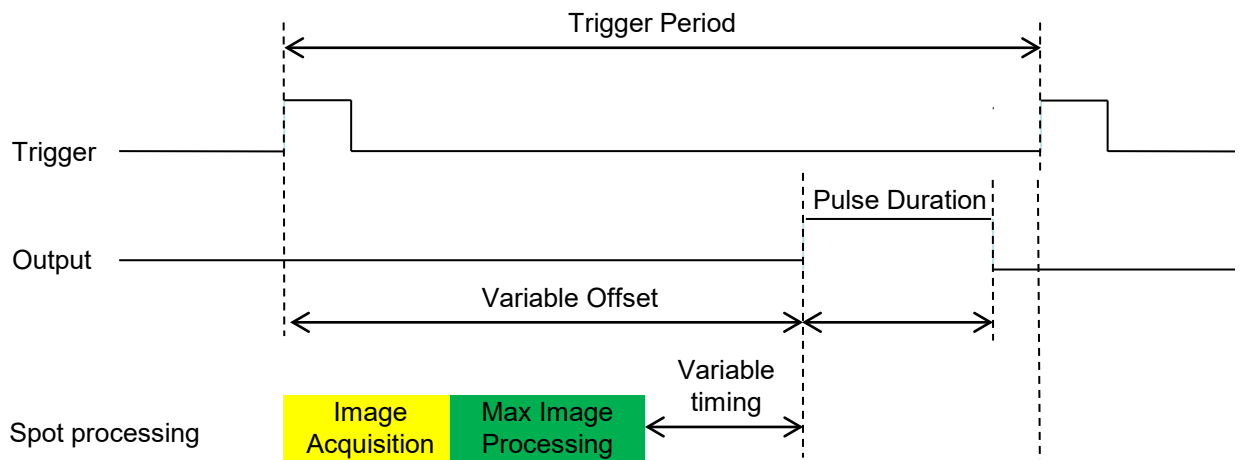

## PL-101 Specifications

The PL-101 module offers additional isolation for the BOA Spot sensor and simplifies wiring at the control panel. The PL-101 is connected to the sensor through a single M12 cordset. **When using the PL-101, Power input PWR must be 24 Volts.**

The I/O and RS-232 connections of BOA Spot are available through the PL-101. Specification for these signals are as follows:

Specification		Definition
Voltage	Load	24 V maximum
Current	GPO[0-2]	200 mA max @ 20°C
Protection	Fuse	PTC fuses to 200 mA at 20°C or 150 mA at 70°C
Common	ICMN/OCMN	PWR or GND as wired on respective OPTOs
Switch Time	GPO[0-2]	800 Microseconds (ON or OFF, includes sensor switch time)

## PL-101 Connections

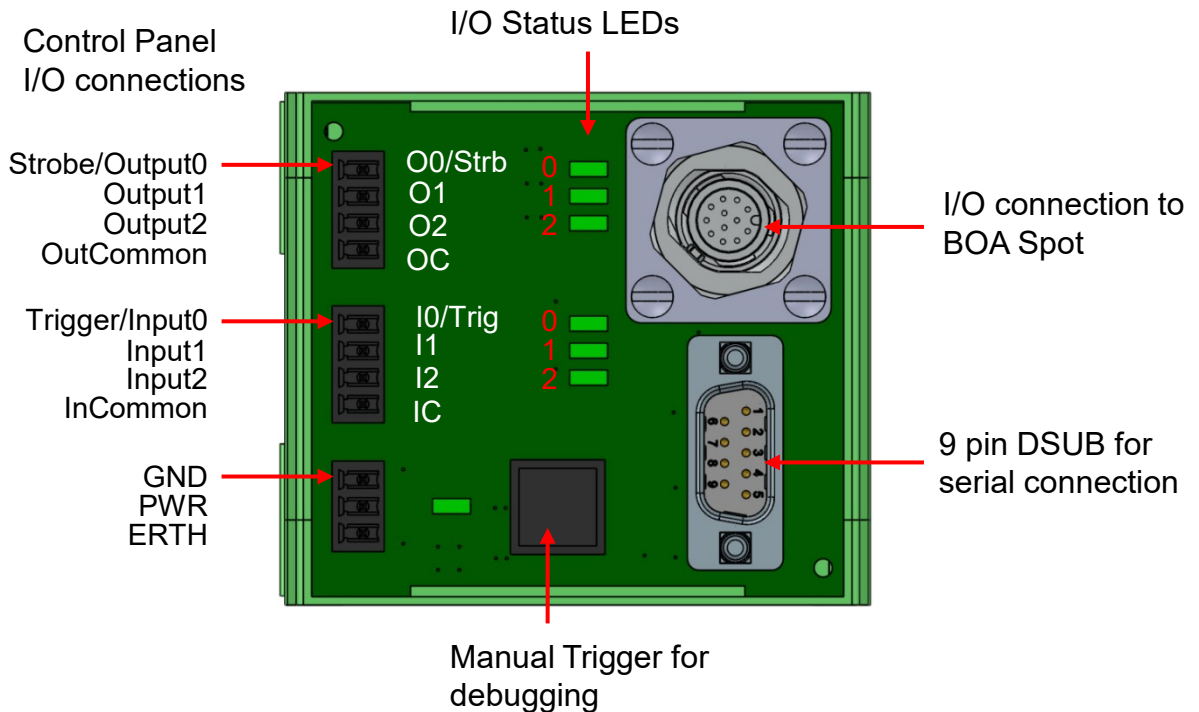

# PL-101 Wiring Diagrams

## Current Sinking Outputs (NPN)

Turning on an output pulls it to 0V.

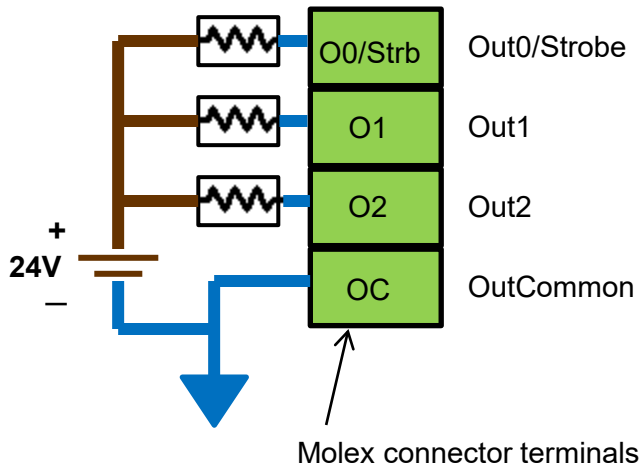

## Current Sourcing Outputs (PNP)

Turning on an output pulls it to 24V.

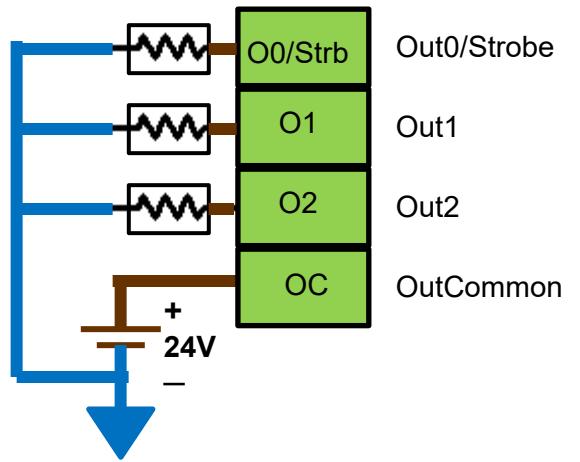

## Current Sourcing Inputs (NPN)

A low voltage turns the input on.

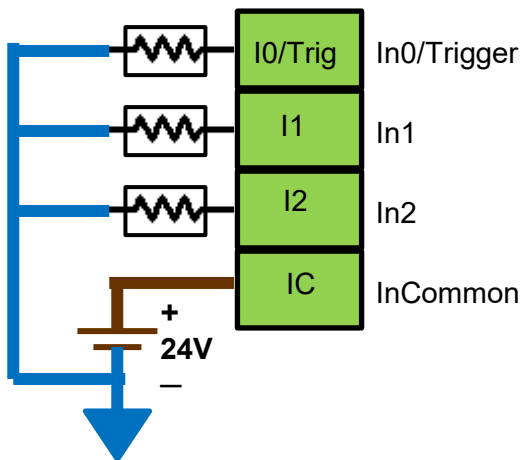

## Current Sinking Inputs (PNP)

A positive voltage turns the input on.

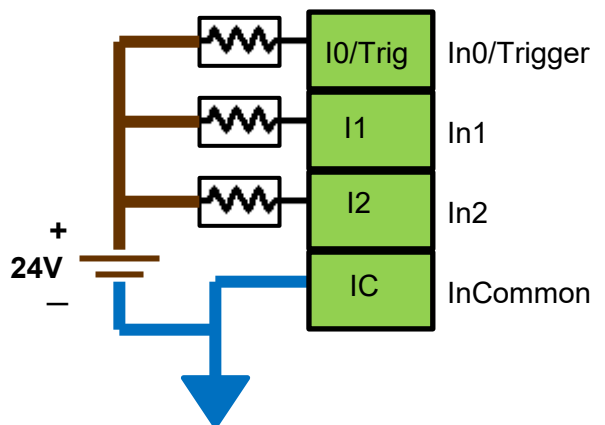

## Serial Port Connection



The RS-232 serial port is exposed through the I/O connector and available on the PL-101 module. By default, the serial port settings are set as follows:

Port definition	Setting
Baud Rate	115200
Data Bits	8
Parity	None
Stop Bits	1
Flow Control	None

These port settings can be changed through the GUI by configuring the “RS232 Stream Settings” in the Setup Control panel. Refer to the on-line help for details.

### RS-232 Hardware Configuration

Electrically, three (3) signals are required to make a serial port connection between BOA Spot and another device as shown below. RS232 is a “point-to-point” connection, so the Receive and Transmit lines must be crossed in the cable.

BOA Spot I/O M12-12 Connector			
Pin	Name	Color	
9	RS232 RX		Red
2	GND		Blue
8	RS232 TX		Gray
1,4,7	Not required		

3 <sup>rd</sup> Party DSUB-9 Connector	
Pin	Name
3	TX
5	GND
2	RX
1,4,6,7,8,9	Not required

**Note:** It is important to establish a common ground connection between BOA Spot and the connecting 3<sup>rd</sup> party device.

## How to Access BOA Spot

The BOA Spot Vision Sensor is supplied with the vision software embedded (already installed). The application runs directly on the device and does not require a PC connection at runtime. A client PC is required to access, setup and store a solution (job file) on the device. We provide two methods for accessing the application from the client PC.

**Note:** The Performance changes on page [33](#) are required for any PC that will access a BOA Spot or use the Emulator. The iNspec application will not work correctly if these changes are not made. The changes to UAC (page [34](#)) and Firewall (page [35](#)) are preferred, but there are ways to work around them.

- **Method 1: Using Nexus for BOA**

Access the BOA Spot web server page (page [36](#)) to download the Nexus application. After Nexus is installed, access iNspec for BOA Spot through the Nexus interface directly, without using a web browser. Nexus provides tools that will be discussed later (page [40](#)).

**Note:** Nexus is designed to manage multiple BOA Spots (and BOAs) and different versions of firmware (“version tolerant”).

- **Method 2: Using the BOA Spot Emulator**

Install the BOA Spot Emulator provided in the BOA Spot software download. Access iNspec for BOA Spot directly, without using a web browser. The Emulator installation provides tools that will be discussed later (page [54](#)).

**Note:** The Emulator version must match the firmware version on the BOA Spot (“version intolerant”). This method requires you to clean (remove) files from the PC using iAssistant, uninstall the Emulator and install a new version if BOA Spots have different versions of firmware.

1. Install the Emulator software.
2. Open the Windows Start menu and expand the group “Teledyne DALSA iNspec Express for BOA Spot
3. Click the shortcut “Connect to a BOA Spot Camera”.
4. Enter the IP Address of your BOA Spot. Enter just the numbers without the web prefix. For example: 192.168.0.100
5. Click OK to connect and launch iNspec Express.

**Note:** For both methods you must configure the network options of the client PC. Follow the instructions starting on the next page.



## Configure the Client PC for BOA Spot Access

**Note:** The paths to some tools depend on the Windows configuration and appearance settings. Some items may appear in the left or the right pane in menus.

### A: System Performance Settings

This will increase the performance of your PC in general and will make the BOA Spot client application perform better. This turns off the visual effects on W7 or W10.

**Note:** The iNspect for BOA Spot application will work incorrectly if you do not perform these steps!

1. Open the Control Panel. Click on “System” & Security”. Click on “System”.
2. Click on “Advanced Settings” or the “Advanced” tab. Under “Performance”, click on “Settings”.

3. Click the Visual Effects tab, shown here.
4. Click the “bubble” beside “Adjust for Best Performance”.
5. Click the check boxes beside “Smooth edges of screen fonts” and “Use visual styles on windows and buttons”. The performance setting will change to “Custom”.

**Note:** Some installations may not have the “Use visual styles...” option.

6. Click “OK”. The appearance will change to resemble Windows Classic.

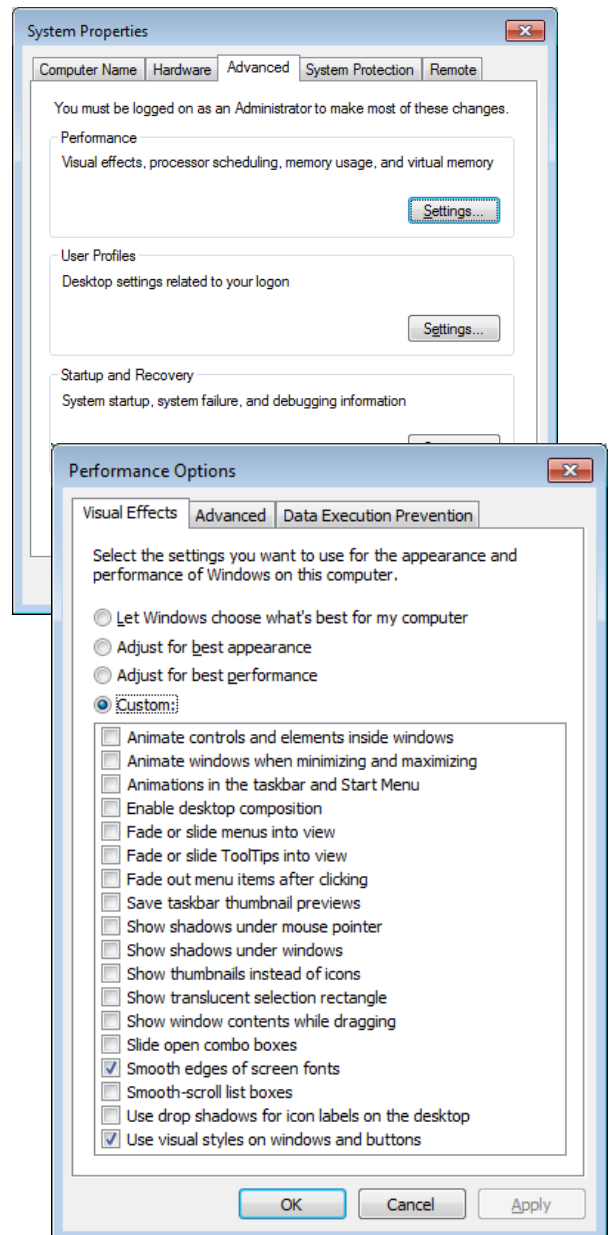

## B: User Account Control (UAC) Settings

UAC will interfere with loading and running the iNspec for BOA Spot software. You will get warning messages when you launch iNspec. You may need to supply an Administrator password depending on the UAC level.

- If your PC is in a closed factory environment not connected to the Internet, and you are using only one administrator account, it is usually safe to turn off UAC. (Your network administrator may not agree or allow this.)
- If your PC is connected to an office network and the Internet, you should use the default or higher security setting, and manually approve software at the prompt messages.

**Note:** If you create multiple user accounts with UAC turned off, the non-administrator accounts will not be asked for an administrative password, and some actions will be cancelled without any notice.

1. Open the Control Panel. Click on “System & Security”. Click on “Change User Account Control”.
2. To turn UAC off, pull the slider all the way to the bottom and then click “OK”.

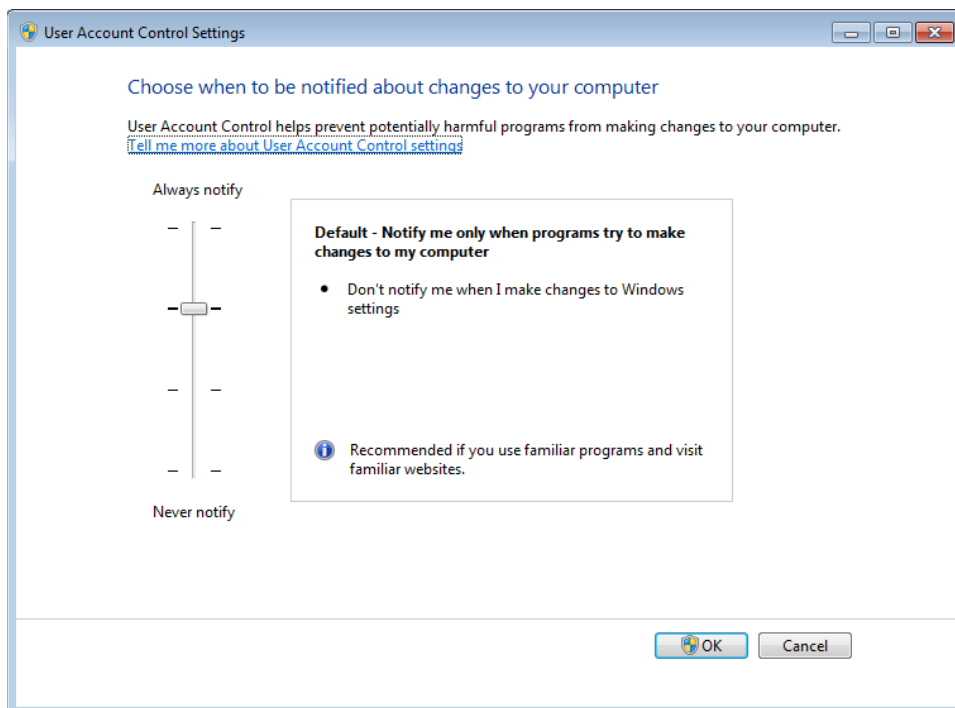

## C: Windows Firewall

BOA Spot communicates with the PC through the Network connection. Windows Firewall will block this communication. It is easiest to turn off the firewall. If you must connect to an office network or to the Internet you can turn the firewall back on.

1. Open the Control Panel. Click on “System and Security”. Click on “Windows Firewall”. If you get a message that says the service is not running, click “No” (do not start the firewall). Skip forward to downloading Nexus.
2. Click “Turn Windows Firewall on or off”. Click the bubble beside “Off (not recommended)” in all categories. Click “OK”.

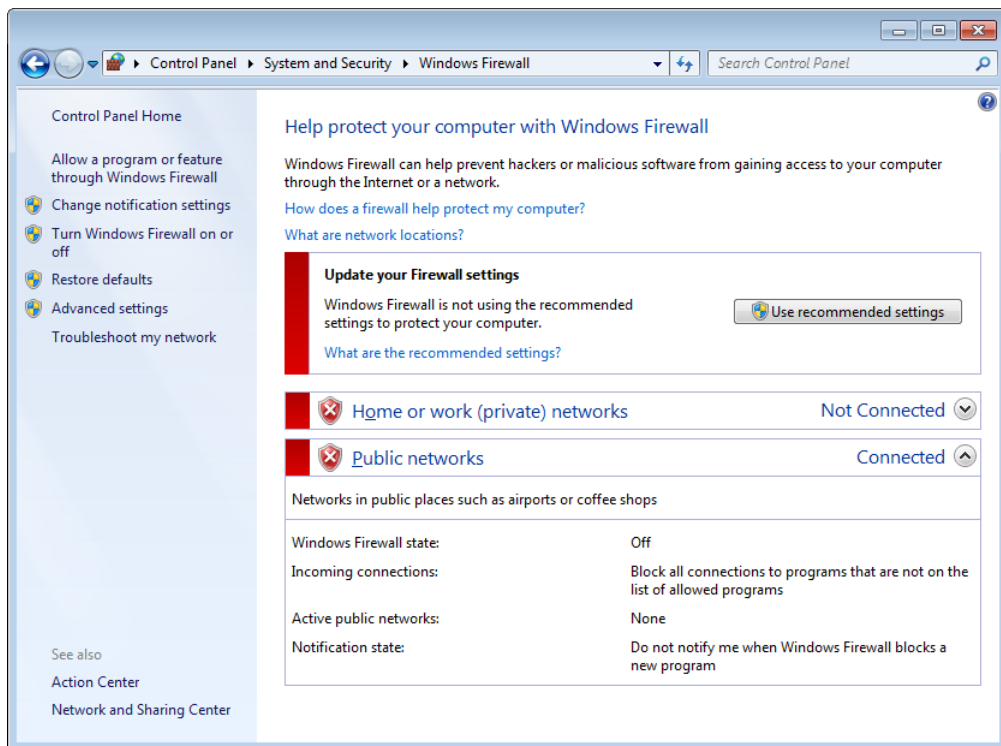

**Note:** If you prefer to leave the Firewall on, you can run the Application and approve each process as it gets reported by the firewall as “potentially unsafe”.

1. Return to the Windows Firewall, and click on “Allow a program or feature through Windows Firewall”
2. Verify what processes are being allowed or denied.
3. Approve processes related to iNspet for BOA Spot.

**Network Ports & Security:** BOA Spot and iNspet require access to use network ports 80 and the range 5005 through 5025 plus any additional ports you configure for TCP communications.

## Download Nexus from BOA Spot

The web server is accessed from a PC (client) using any web browser, as follows:

1. If you have not yet changed the BOA Spot default address, the PC used to access BOA Spot initially will need to be configured on the same network neighborhood, but with a different address (i.e. 192.168.0.1). Consult your system administrator for instructions on how to do this. The subnet mask should be set to 255.255.255.0
2. Open a web browser and enter the BOA Spot address (192.168.0.100) in the address bar, and click “Go” or press Enter.
3. The BOA Spot web server home page is displayed in the browser, as shown below. The web server provides a quick snapshot of the state of the BOA Spot and provides a download for the Nexus application which provides access to the BOA Spot.

**Note:** The default address range 192.168.x.x is very popular. If you are using a Laptop or PC with a wireless adapter, you may need to disable the WIFI to reach the BOA Spot at the factory default address.

4. Click on the link for “Nexus Application Software” and save the file to your PC.
5. After the download has finished, you may close Internet Explorer.
6. You can now change your PC back to the original IP Address.

**Note:** 192.168.0.100 is a default address used by many network enabled devices. You should change your BOA Spot to a different address.

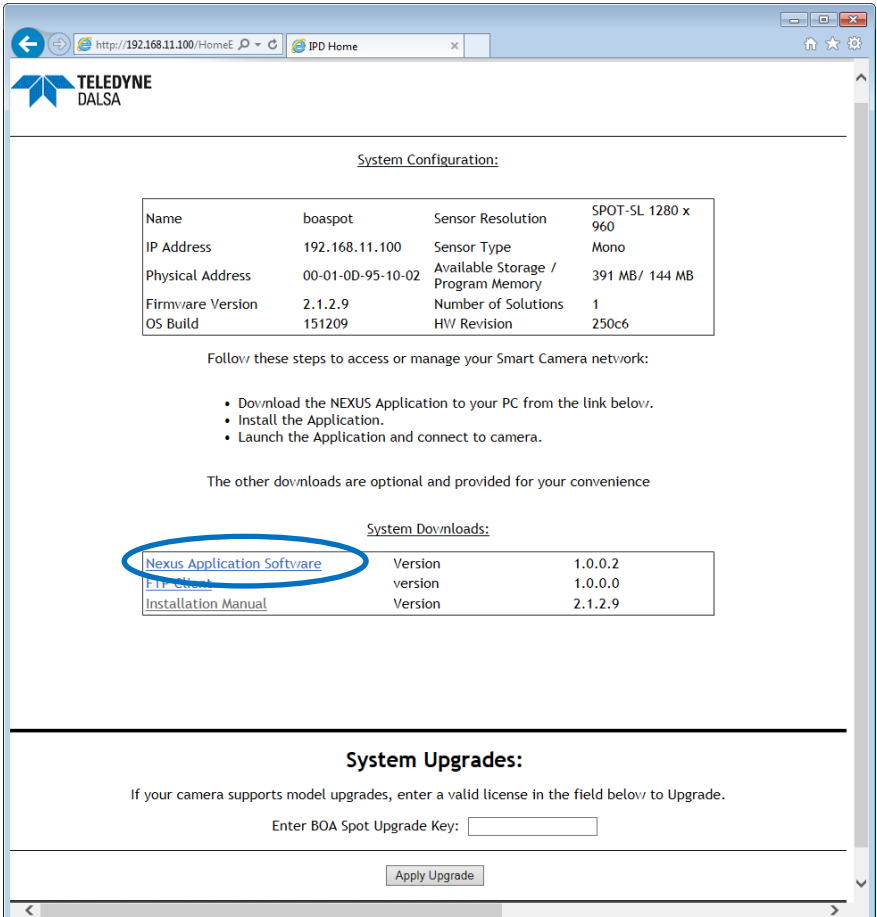

The screenshot shows a web browser window with the URL <http://192.168.11.100/HomeE>. The page header features the TELEDYNE DALSA logo. The main content area is titled "System Configuration:" and contains a table with the following data:

Name	boaspot	Sensor Resolution	SPOT-SL 1280 x 960
IP Address	192.168.11.100	Sensor Type	Mono
Physical Address	00-01-0D-95-10-02	Available Storage / Program Memory	391 MB / 144 MB
Firmware Version	2.1.2.9	Number of Solutions	1
OS Build	151209	HW Revision	250c6

Below the table, it says "Follow these steps to access or manage your Smart Camera network:"

- Download the NEXUS Application to your PC from the link below.
- Install the Application.
- Launch the Application and connect to camera.

The other downloads are optional and provided for your convenience

Under "System Downloads:", there is a table with the following data:

<a href="#">Nexus Application Software</a>	Version	1.0.0.2
<a href="#">Firmware</a>	version	1.0.0.0
<a href="#">Installation Manual</a>	Version	2.1.2.9

The "Nexus Application Software" link is circled in blue. At the bottom of the page, there is a "System Upgrades:" section with a text input field for "Enter BOA Spot Upgrade Key:" and an "Apply Upgrade" button.

7. Open the Downloads folder on your PC.
8. Right-click on “Nexus.exe” and select “**Run as Administrator**”.

After the installation, the following related shortcuts will be available from the Windows Start menu at: [Start->All Programs->Teledyne DALSA->Nexus for Boa](#)

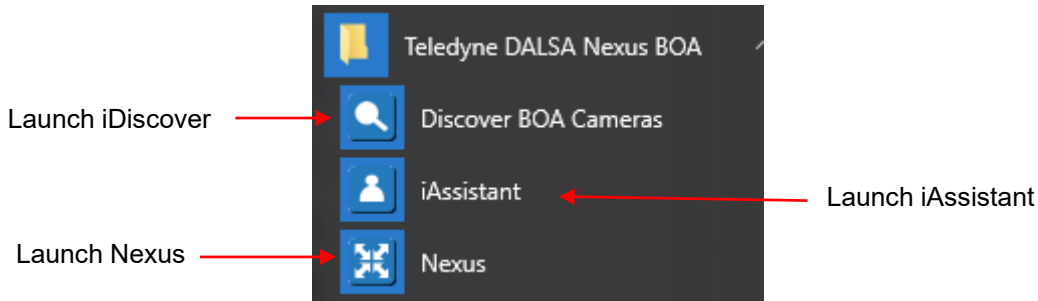

**iDiscover** is used to set the BOA Spot IP Address or change the Device name. You can use this shortcut to launch iDiscover (page [38](#)) or you can use the Nexus application to change a BOA Spot’s address (page [40](#)).

**Note:** All BOA Spot sensors are shipped with the same address and name. It is necessary to change the address if more than one BOA Spot is on the network. Changing the name is optional but is recommended, to avoid confusion.

**iAssistant** is used to clean up (delete) outdated files on the PC (page [50](#)). Nexus can manage multiple versions of the BOA Spot firmware. However, cleanup may be needed if you run into issues. **Note:** If you use this shortcut to launch iAssistant right-click on the shortcut and select “Run as administrator”. Or you can use the Nexus application to launch iAssistant.

**Nexus** is used access and manage the BOA Spot and open the GUI programming or Client application (page [39](#)).

## The iDiscover Utility

The iDiscover utility attempts to discover all BOA Spot sensors connected to the local network. You can use this utility or Nexus to change a BOA Spot's address.

1. Open iDiscover from the Windows Start menu:

Start->Programs->Teledyne DALSA->Nexus for BOA->iDiscover

The left panel (below) shows the MAC addresses of all reachable BOA Spot sensors. Blue cameras have compatible addresses. Red cameras have incompatible addresses.

2. Click on a camera, to populate the associated network configuration on the right.
3. You can then change the BOA Spot IP address to match the associated NIC settings displayed at the top right, and then click "Apply". You can also change the default Device Name in this window.

**Note:** The "Connect to Device" button opens Internet Explorer and connects to the BOA Spot web server's home page (page [36](#)).

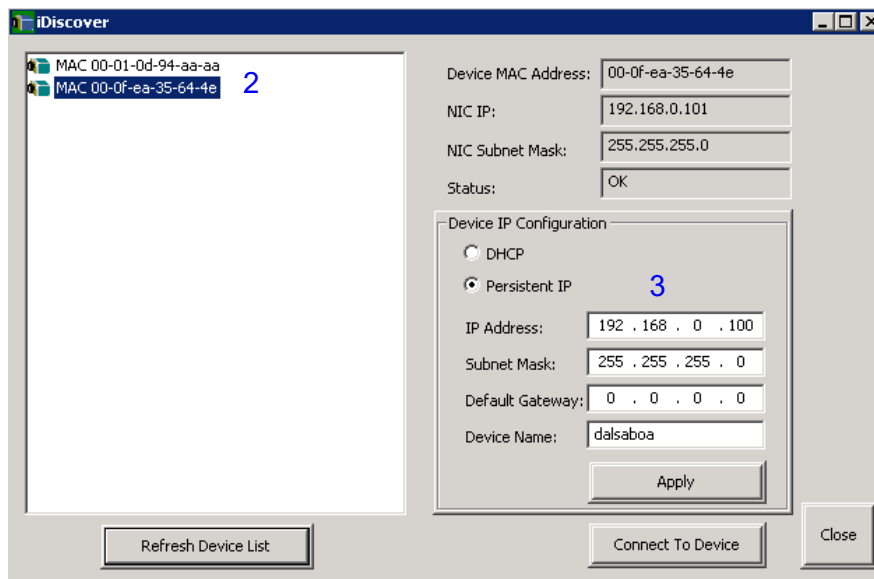

**Note:** If all the fields on the right are blank, it may mean the PC and the BOA Spot have the same IP address. Windows cannot support this condition. Change the PC's IP address (Network Adapter Settings in Windows) to access the BOA Spot and change its address. Please refer to page [57](#) for more suggestions.

**Note:** WIFI or wireless LAN adapters can interfere with connecting to BOA Spots using the address range 192.168.x.x.. If you have trouble, temporarily disable the WIFI adapter and configure the BOA to a different address range.

## Launch the Nexus Application

1. Open the Nexus application from the Windows Start menu (pictured on page [37](#)):

**Start->Programs->Teledyne DALSA->Nexus for BOA->Nexus**

Nexus will scan your network for connected BOA Spot (and BOA) devices. This may take up to a minute or more. The next time you open Nexus it should take less time.

The Nexus interface is shown below. The Status field at the bottom will first show “Discovering” while Nexus finishes scanning for BOA Spot and BOA devices. The Status changes to “Ready” and the “Cameras” field displays all BOA Spot and BOA devices. See page [58](#) if no cameras are listed after you refresh.

2. Click on a BOA Spot in the “Cameras” list and all buttons become active.
3. Click on “Settings” to change camera settings (page [40](#)).
4. Click on “Connect” to open the iNInspect for BOA Spot application (page [41](#)) and begin job programming.

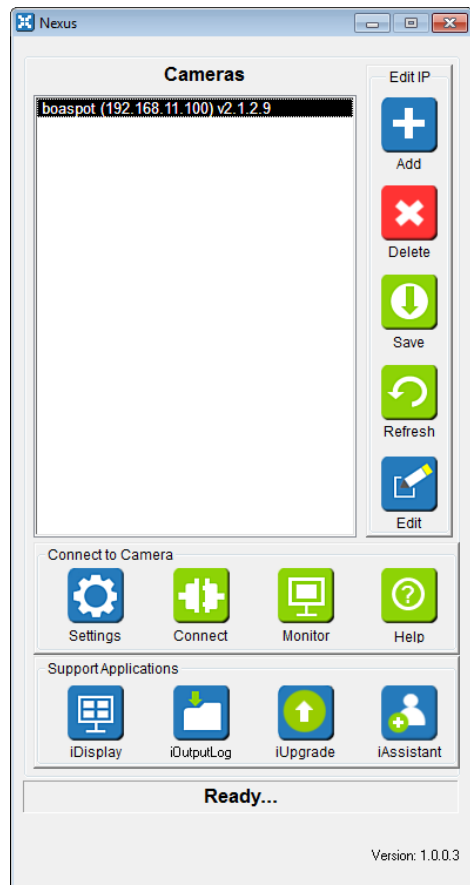
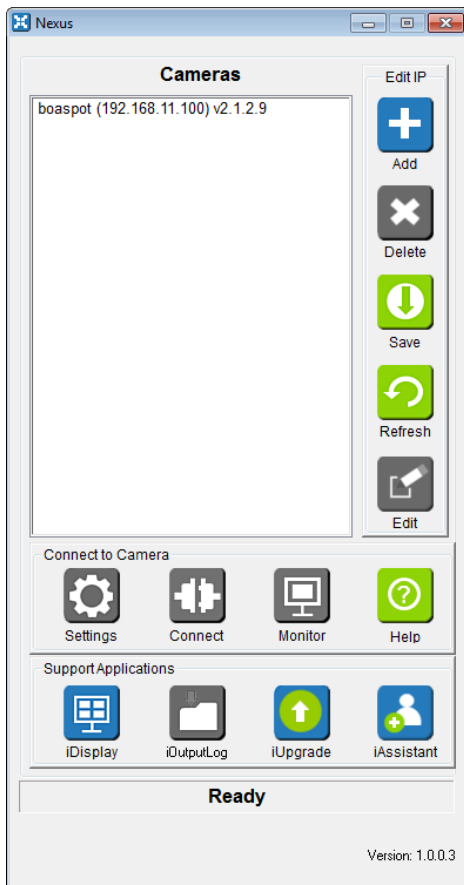

## Change BOA Spot Address

If the BOA Spot name and address appears in Red, the address is not compatible and must be changed.

1. Click on the red BOA Spot in the list, and then click the “Edit” button.
2. Use the “Resolve Camera Settings” window to change the BOA Spot IP Address (shown in the bottom half) to be compatible with the NIC IP on your PC (shown in the top half). You can also change the BOA Spot device name if you wish.
3. Click “Apply” and then click “Close”.
4. The Nexus application rescans your network for the BOA Spot at its new address.

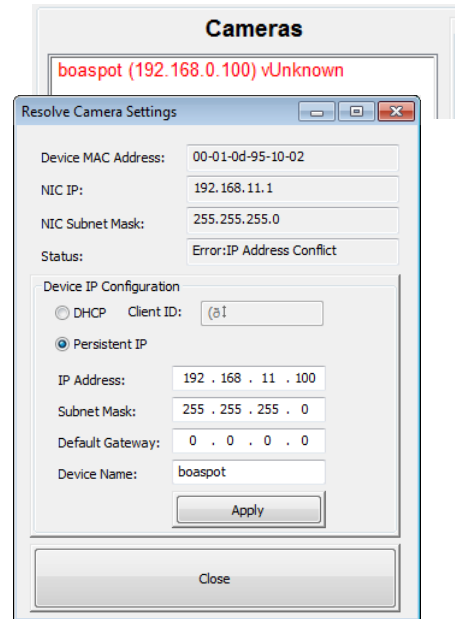

**Note:** A network switch or router can interfere with changing the address. Connect the BOA Spot directly to the PC to change the address. Reinstall the router and use the Add button in Nexus to manually add the BOA Spot address to the list and save.

## Change BOA Spot Settings

1. In the Nexus application window (page [39](#)), click on a Camera, then click “Settings”.
  - You can enable “Recycle” tolerances in measurements.
  - You can enable a specific Solution (job file) to load when BOA Spot is powered on.
  - You can enable using a “Template Solution” file to use your defaults in new Solutions.
  - You can change the display language in the iNspect application software.
2. When you are finished, click “Apply and Reboot” to apply your new settings. The BOA Spot will reboot.

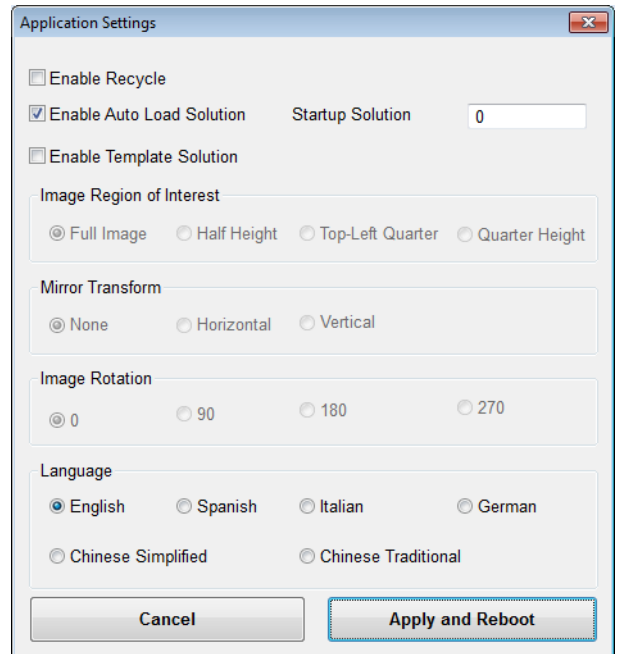



# Programming the BOA Spot

## iInspect for BOA Spot Application Interface

The “Connect” button in the Nexus application launches or opens the BOA Spot Application. The BOA Spot application window has three panels. The left panel is for Instruction and Setup. The large right panel is for displaying the Image, and drawing tools. The bottom right panel is for Configuration and displaying Status. The top right panel is the Navigation bar. You can resize the panels.

**Definition:** Inspection job files are called “Solutions”. You configure (program) and save a “Solution” to the BOA Spot memory. BOA Spot runs or switches between Solutions stored in its memory. You can also export your Solutions to the client PC.

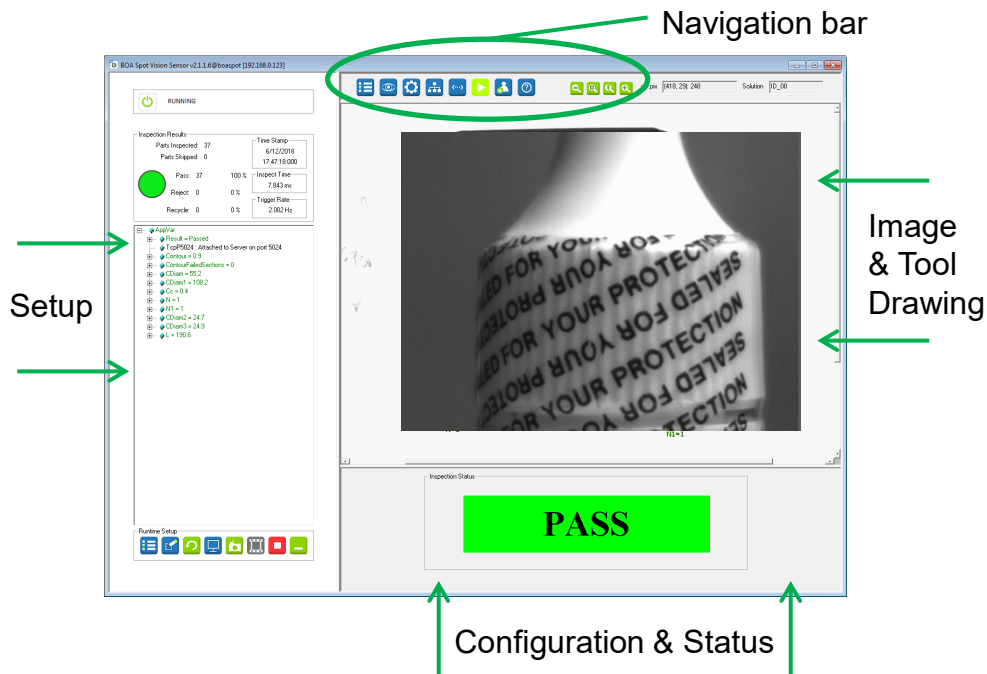

The BOA Spot application will open to the Select Solution (as shown) if there is no Solution currently running. The application opens to the Run panel if a Solution is currently running. The run status is displayed at the top of the Instruction & Setup panel.

- When you apply power to the BOA Spot, it will load and start running Solution0, if you have “Auto Load” enabled, and if there is a Solution0 saved in the BOA Spot memory.
- If there is no Solution0, or you do not have “Auto Load” enabled, BOA Spot opens to the Select Solution panel and waits for you to load a Solution, or start a new Solution.
- If BOA Spot is running, it will **continue running and inspecting** when you close the quit or application window. The application window runs on the PC only.

## Getting Started

The following steps show how to setup a basic Solution on BOA Spot. More detailed information is available by clicking the help button in the Navigation bar.



1. Click on “Solution Setup” in the Navigation bar.



2. Click on the “Start New Solution” button in the Setup panel.



3. Click on “Sensor Setup” in the Navigation bar.



Setup the trigger source, exposure and light controls for your application.

Use the interactive features to adjust the lens aperture and focus. The goal is to achieve an optimal high contrast image.

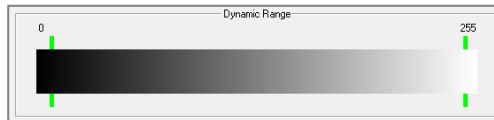

Optimize image range

Maximize distance between green bars to optimize dynamic range.



Optimize image focus

Matching numbers indicate lens is at optimal focus.

4. Click on “Tool Setup” in the Navigation bar.



5. Click on the green “Take a Picture” button to snap an image. If you are using triggered acquire, click the “triggered snap” button to the right. It will be green if trigger is enabled.



- Click on the tool you want to use in the “Select Tools” panel. The SL model tools are shown on the left, with the Intensity tool selected. The IDS model tools are shown on the right, with the Barcode tool selected. Page 8 lists all the available tools.

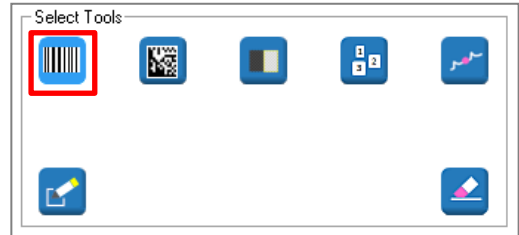
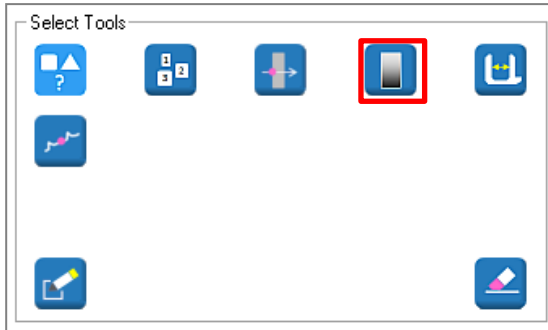

- Draw the Region Of Interest (ROI) on the image in which the tool will inspect. This can be the whole image or a subset of the image. You can construct a single or multiple ROIs if required.



The Intensity tool makes a measurement and populates the pass/fail tolerances. You can right-click on the ROI outline to open the tool’s property panel, where you can change the tool’s defaults and settings.

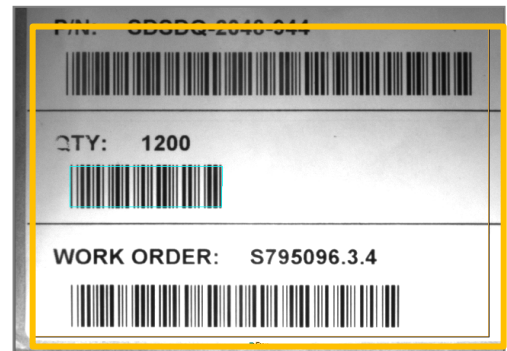
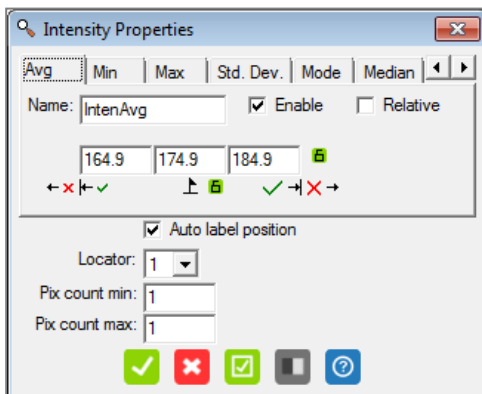

The Barcode tool reads the first code it finds (usually closest to the center). Right-click on the ROI outline to open the property panel, where you can change the expected number of codes.

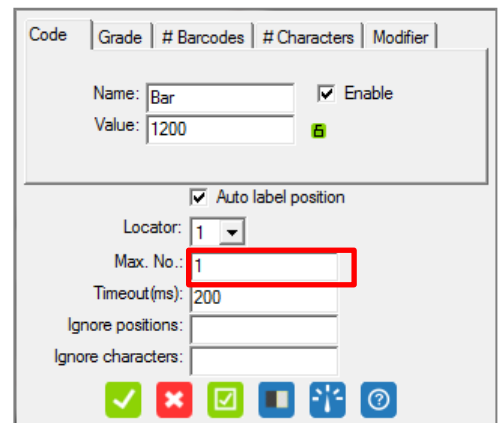

8. Optionally: Click on “Setup Communications” in the Navigation bar.



This panel is where you would setup connections to outside devices (i.e. PLCs or storage devices) for control/status communication.

Select Connection: TCP/IP Stream ← Select connection method

TCP/IP  
Our Role:  Client  Server  
Device IP: 140 . 165 . 86 . 0 Port: 5025  
Var Name: TcpP5025  
+ ← Add connection method

Delete Connection: Server on port 5024  
× ← Delete connection method

Setup I/O: [I/O icons] ← Set up discrete I/O (next page)  
Setup Image Logging: [Image Logging icon] ← Set up image logging to the attached client PC

After a connection has been established, the script tool is used to define what is communicated between BOA Spot and the connected device(s). Typically this is inspection results or application controls, such as selecting which solution to run for a given process.

For more detailed information please refer to the on-line Help, the *BOA Spot Communication Guide* and the *BOA Spot Scripting Guide*.

## Image Logging



Two methods of image logging are supported. If a client PC is connected at runtime, images can be logged directly to the PC drive. If no client is connected at runtime, Image logging can be setup to a networked device using the FTP protocol using the scripting editor.

**Note:** Image logging affects performance and is not recommended for time critical applications.

## Setting up Inputs



The BOA Spot application provides options for controlling the inputs. These are selected in “Setup Connections” in the “Configuration” panel as shown below. Click on the GUI table cells to change the control parameters.

Input	Control	Debounce (us)	Triggers Per Image	Value
Trigger (GPIO)	Active High	200	1	0
GPI1	Input			0
GPI2	Input			0

Click on the trigger “Control” cell to open a drop list to change the trigger input polarity.

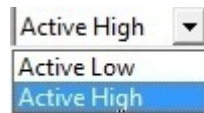

Each input supports a noise filter called “debounce”. A signal must remain active for the duration of the debounce to be considered valid. The debounce settings range from 1us to 64ms. GPIO is a special input that is used either as a Trigger or general purpose input. When used for triggering, the polarity of this input is programmable.

BOA Spot inputs are available to the script tool for synchronizing with external events. They can also be used as “Job Change” and “Job Select” inputs for hardware job switching (refer to page [26](#)).

## Setting up Outputs



The BOA Spot application provides two options for controlling the outputs. These are selected in “Setup Connections” in the “Configuration” panel as shown below. Click on the GUI table cells to set the Driver, polarity and associated pulse parameters.

Output	Driver	Polarity	Pulse Offset (ms)	Pulse Duration (ms)	Initial Value
GPO0	Pass Soft Pulse	Active High	0	40	0
GPO1	Fail Soft Pulse	Active High	0	40	0
GPO2	Script Setting	Active High	0	1	0

Click a cell in the “Driver” column to open a drop list to change the output source.

GPO2 can also select a “Strobe Pulse”.

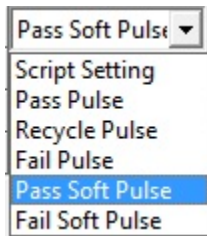

Click a cell in the “Polarity” column to change the output polarity.

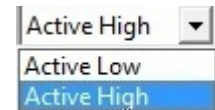

**Note:** The Strobe driver uses the offset/duration settings defined in the sensor panel. The active polarity only affects the external STROBE output.

Each BOA Spot output can be configured by an equation in the script tool or a programmable pulse based the inspection result (either Pass, Fail or Recycle):

**Script Setting:** Use the script tool to configure an output to provide a programmable level or a pulse based on the application need (**Note: the GUI pulse settings are disabled in this mode – shown as dark gray above**). Script selection is non-deterministic, meaning the output timing may vary if the processor is heavily loaded. This may occur, for example, when the trigger and inspection times are close and BOA Spot is serving images to a connected PC.

**Example:** A script equation that generates an active high 10 ms pulse based on a PASS result would be:

**If (Result = 1) Global.GPO[0] = pulse( 1, 0 ,10)**

“Soft Pulse” Setting: Selecting this setting will automatically define scripts based on the pulse settings defined in the GUI. This offers a convenient alternative to learning the script tool if you only need to generate a pulse output.

“Pulse” Setting: This mode offers a deterministic output with an offset and duration synchronized to the incoming trigger. In this mode, the output will pulse IF the result is TRUE and the total inspection time is less than the pulse offset from the trigger. If the pulse offset is too short, BOA Spot will not generate a pass pulse even if the inspection passes. In this case, BOA Spot will always generate a FAIL pulse if FAIL is selected on any output. This would result in false rejects if the output is being used to control a directional device.

**Min Pulse Offset = Exposure Time + Acquisition Time + Inspection Time**

Example: Pulse 10 ms on GPO0 for a PASS result OR pulse 30 ms on GPO1 for a FAIL result. Sensor exposure time is 9 ms, acquisition time is ~16 ms and inspection time is ~35 ms. Minimum Pulse Offset = 9+16+35=60 ms. IF the minimum offset is satisfied, BOA Spot will output a PASS pulse on a good result, ELSE BOA Spot will output a FAIL pulse instead. The duration of the pulse is not significant in this decision. However, setting the pulse longer than the trigger period is not advised. **The maximum pulse offset and duration is 16 seconds.**

**Note:** Processing overhead can also affect the minimum pulse offset requirement. It is good practice to calibrate this time based on your typical expected usage of the system (i.e. inspection time overhead + system access overhead)

9. Optionally: Click on “Edit Script” in the Navigation bar.



BOA Spot offers a basic scripting tool for application control. If you are setting up a complex inspection (not typical with BOA Spot) or handshaking with connected devices, the script tool provides a lot of flexibility.

You do not need to use the script tool for basic applications. Refer to the on-line help for more details.

There is also a “BOA Spot Scripting Guide” located in the software download file.

10. Click on “Run Solution” in the Navigation bar.



Here you can test the solution to see if it meets the inspection objective.

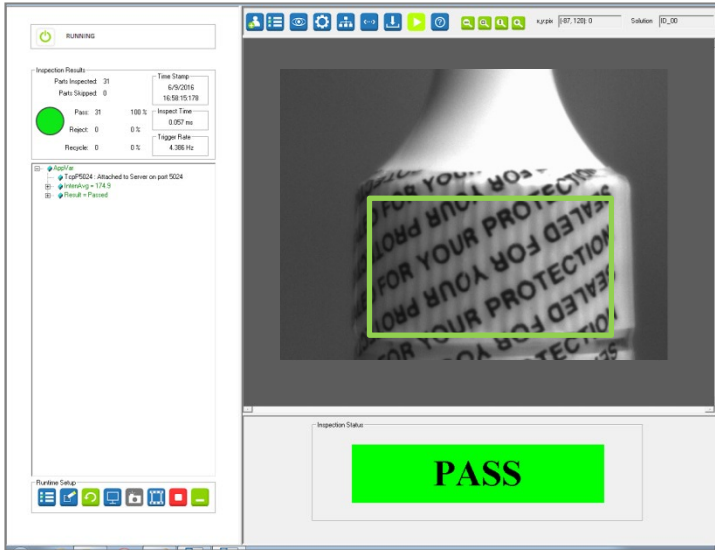

11. Click on “Solution Setup” in the Navigation bar.



When you are satisfied with the solution, you can save it on the BOA Spot vision sensor using this panel. You can save up to **32** Solutions.

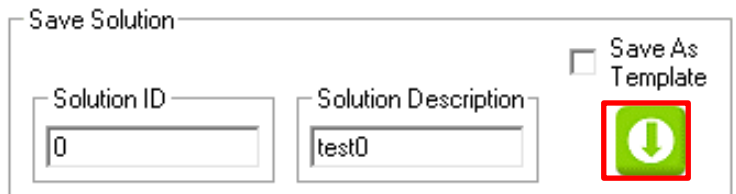

Enter a description (name) and ID number for the Solution, then click the “Save Solution” button. The solution can be automatically loaded on power up, or by using discrete I/O, or by using commands from a connected device.

This “Save” panel allows you to export solutions to a connected client PC for backup. You must save a solution on the BOA Spot before it can be exported.

12. Once you have saved, you can create another Solution, or close the application. The BOA Spot will continue running the current “job” or “Solution”.



## Upgrade BOA Spot Firmware

BOA Spot firmware may need to be updated to add new features or fix reported problems. We recommend against upgrading if the current firmware is performing to your expectations.

Obtain the binary upgrade file from the BOA Spot software download file, or from your Teledyne Imaging representative. Copy the file to the client PC. When you upgrade by any of the methods, you need to browse to the location of the binary file.

**Note:** Export your saved solution files before upgrading the firmware.

There are two ways to open the upgrade utility:

- Nexus installed: open Nexus (page [39](#)) and click the “Launch Upgrade Utility” button.
- Emulator installed: open the Start menu (page [54](#)) and click “Upgrade firmware of a Boa Spot Camera”

1. Click the “Browse” button and find the binary upgrade file. Click “Preserve Solutions” if desired.
  2. Check all the devices you want to upgrade. The camera list shows all BOA Spots on the network.
  3. Click “Upgrade Selected”.
- The BOA Spots are upgraded **one at a time** and rebooted.
4. Close the utility after all upgrades are completed.
  5. If you use the Emulator link to connect to the BOA Spot, use iAssistant (page [50](#)) to delete outdated files (not needed if you use Nexus).

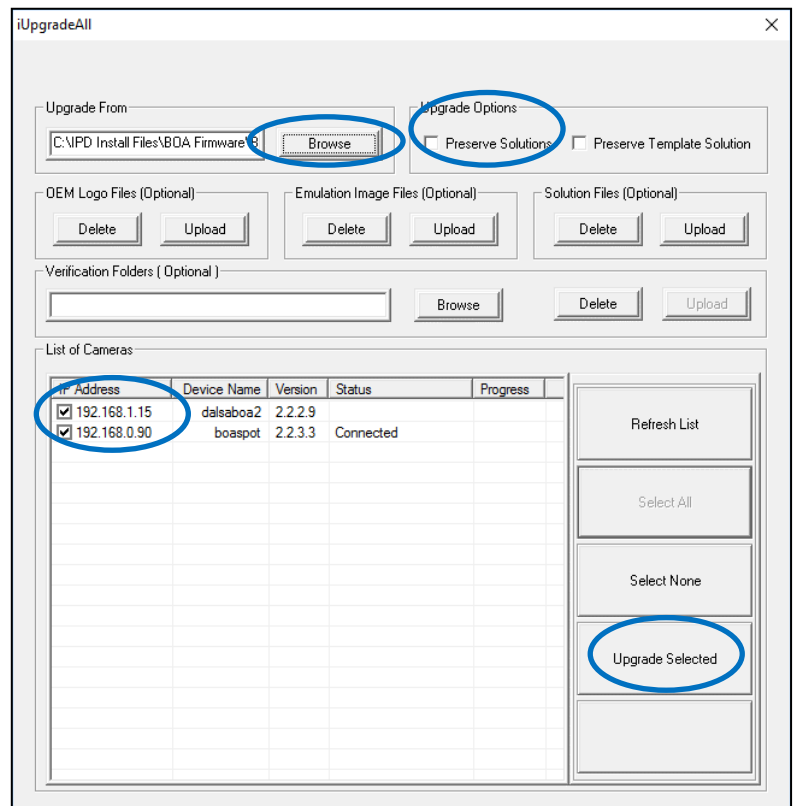

6. Uninstall the Emulator. Reboot the PC and install the new Emulator version that matches the new firmware.

## The iAssistant Utility

After a firmware upgrade, PC can be “cleaned” of outdated software components associated with the previous firmware. Nexus usually updates itself, but there are still times when you should clean the files.

There are a few ways to access the iAssistant utility.

- From the Start menu if you have installed Nexus (page [37](#)) or the BOA Spot Emulator (page [54](#)) or from the Nexus application (page [39](#)).
- From the Nexus Application click the “iAssistant” button.

1. Close all other BOA Spot windows, and Internet Explorer.
2. Open iAssistant using one of the methods listed above.
3. When the iAssistant application opens, click the “Clean” button. All the files in the list will be deleted.
4. Click “Close”.

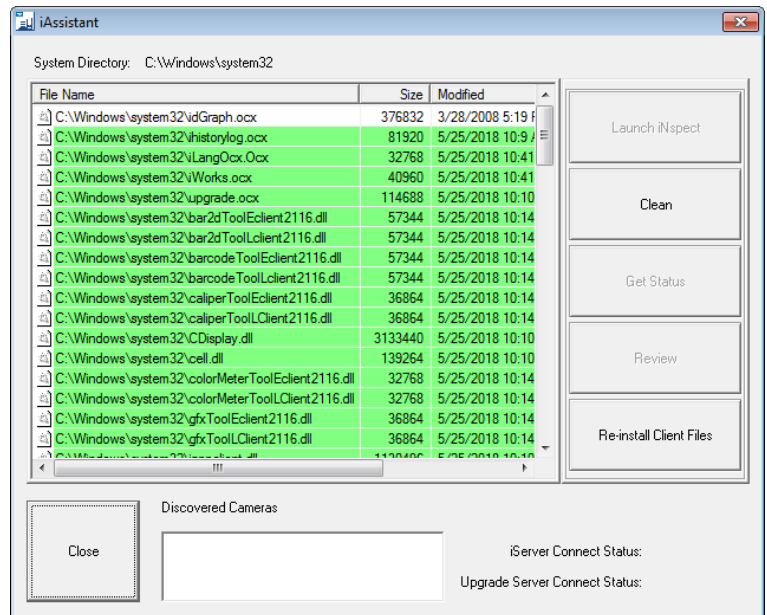

**Note:** If you get error messages and not all the files are deleted, verify Internet Explorer and all BOA Spot related applications are closed. If you continue to get errors, reboot the PC and run iAssistant again. If you open iAssistant from Nexus, it has full Administrator privileges, and can delete all files. If you open iAssistant from the Start menu shortcut, it does not have administrative privileges and may not delete all files. From the Start menu right-click on the shortcut and select “Run as administrator.”

The updated iAssistant uses a color display to inform you of file status or issues that you need to correct.

Nexus is designed to manage files for multiple versions of BOA and BOA Spot firmware. The core components are usually kept at the latest version and some tool-specific files from older versions may be added to ensure backwards compatibility.

- No highlight indicates non-critical or non-versioned files.
- **Green highlight** indicates the files are the newest version that Nexus has found.

No action is required.

1. Click Close.

- **Blue highlight** indicates Nexus has downloaded some files from an earlier version, to maintain compatibility. These are usually tool specific files.

No action is required.

1. Click Close.

- **Red highlight** indicates important files are outdated. The iNspec application may not work correctly.

Your action is required:

1. Click “Clean” to remove all files.
2. Then click “Reinstall Client Files”.
3. Wait for the list to fill again before closing.
4. Click Close.

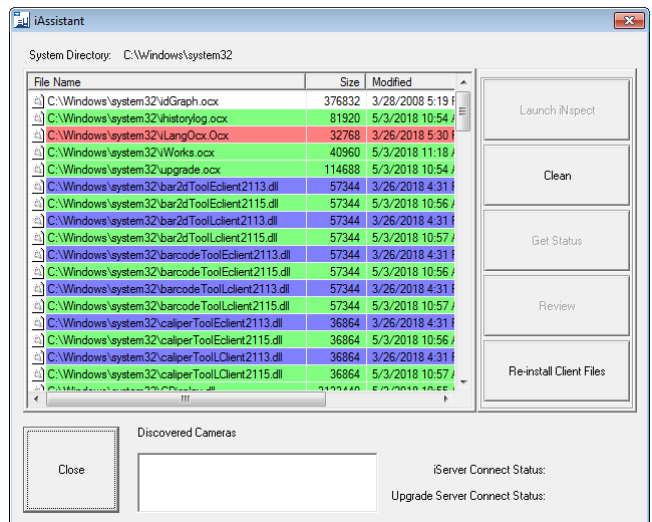
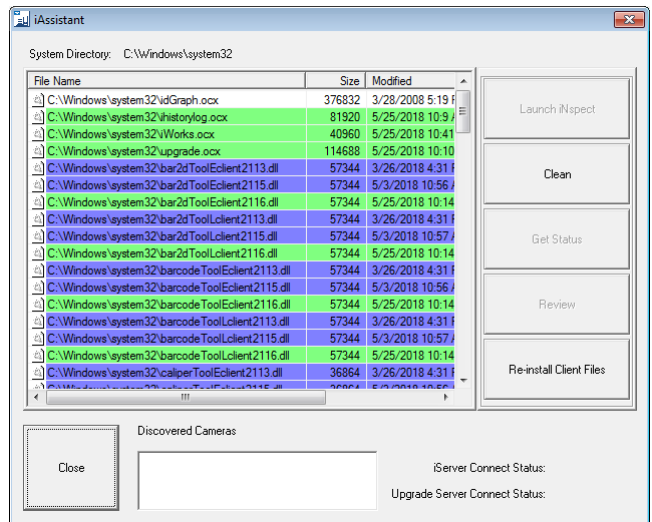

**Note:** If you get error messages and not all the files are deleted, verify Internet Explorer and all BOA Spot related applications are closed. If you continue to get errors, reboot both the PC and BOA Spot, and run iAssistant again.

## The iDisplay Program

iDisplay is an application developed for PCs and Win32 based HMI's that can display images and results from up to 8 BOA cameras. It is installed with the Nexus application or the Emulator software. The application provides the following features:

- Multiple, simultaneous image update with graphics and zoom
- Selectable results panel (select by IP address of camera)
- Solution switching and history recall by camera
- Manual triggering
- Tolerance editing for privileged users
- Customer logo (installed using the "iUpgrade All" utility)

There are two ways to launch iDisplay. Open the Nexus application and click the iDisplay button, or use the Windows Start menu shortcut if the Emulator software is installed:

**Start>All Programs>Teledyne DALSA>iNspect Express Emulator for BOA>iDisplay**

When launched for the first time, the dialog on the right will prompt you to select which cameras to connect for display. The list on the right shows all the cameras that were found on the network segment. Click on a camera to add it to the configuration. Click "OK" to launch the program.

Next time the program is launched, it will only try to connect to the cameras selected in the dialog. If any cameras are not available, it will connect only the cameras that are.

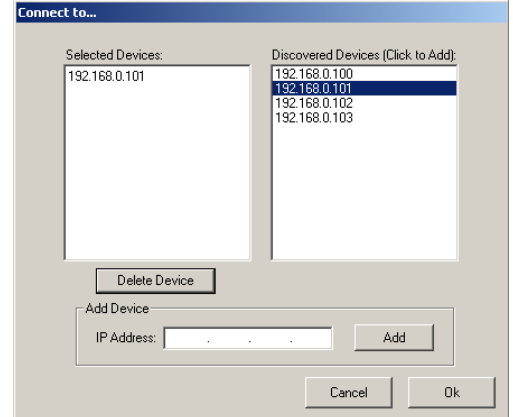

**Note:** The camera configuration can be changed by clicking the "Configure" button in the iDisplay GUI or launching the iDisplay program from the command prompt with the config switch - "iDisplay /config". You can add or delete cameras to the list.

The order of cameras in iDisplay is based upon their order of discovery. The order is not configured or controlled separately. This means they may show in different order after a system reboot. You can delete all but one camera and add them back in the order you wish.

Below is a screenshot of the iDisplay application connected to 4 standard BOA cameras. The panel on the left shows the results from the “Active Monitor”, indicated in the upper right corner of the associated image window. The active monitor can be changed by selecting the device IP address in the drop-down menu.

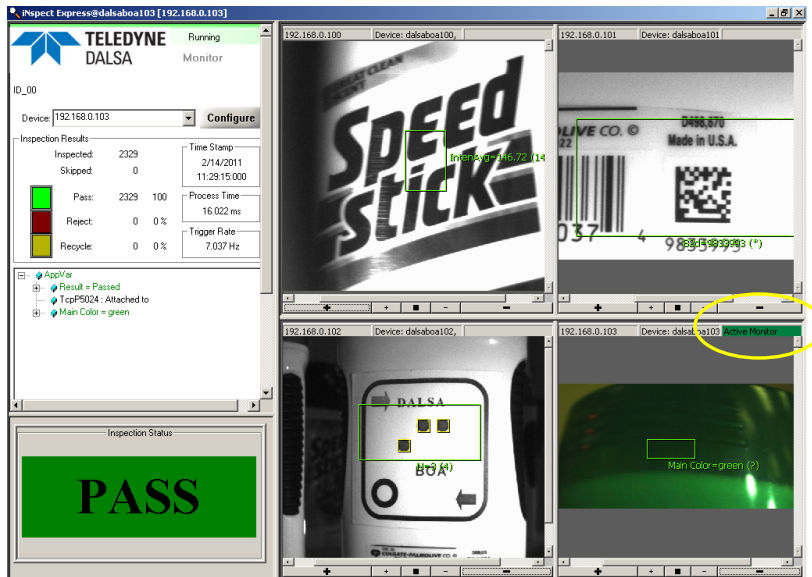

Scrolling the left panel will expose controls for changing solutions, viewing history and configuring display updates on the selected camera.

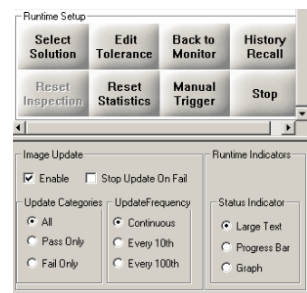
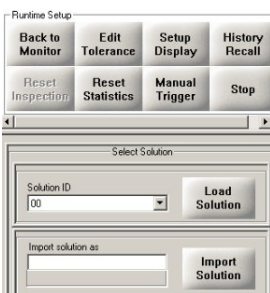

**Note:** iDisplay is built on the same framework as iInspect Express and includes the same runtime controls.

## The BOA Spot Emulator & Complementary Programs

The BOA Spot vision system is shipped with a full-featured emulator that allows you to prepare or debug solutions offline. The emulator is available in the software download file and is easy to install.

The emulator installation offers a number of complementary programs and an alternate way to access the BOA Spot application. After the installation is complete, the following related shortcuts will be available from the windows start menu:

Start>All Programs>Teledyne DALSA>iNspect Express Emulator for BOASpot

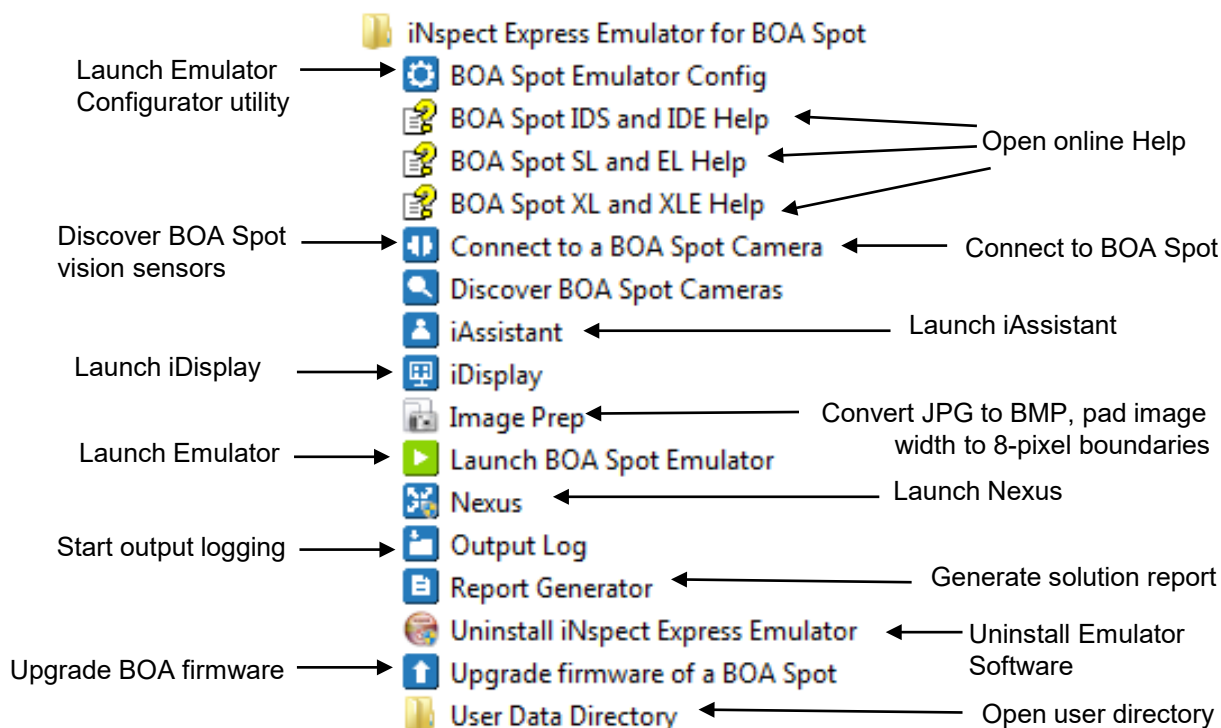

**ImagePrep** utility converts JPG images to BMP and increases the line width to the next 8-pixel boundary if needed.

**Note:** When you access BOA Spot through this interface, it is important that you **maintain version compatibility** between the sensor and the client.

**Note:** BOA Spot Emulator software is compatible with Windows 7 and 10. Not compatible with Windows XP.

**Note:** It is important to use the “BoaSpot Emulator Config” the first time after installing or upgrading this software.

## The BOA Spot Emulator Configurator

This utility provides a quick and easy way to setup the emulator. It is launched from the windows start menu:

Start>All Programs>Teledyne DALSA>iNspect Express Emulator for BOA Spot>BOA Spot Emulator Config

Select the BOA Spot model, and location of the stored images, then click “Launch Emulator”. If the images don’t match the standard BOA Spot resolutions exactly, clear the “Use Matching Image Files” option.

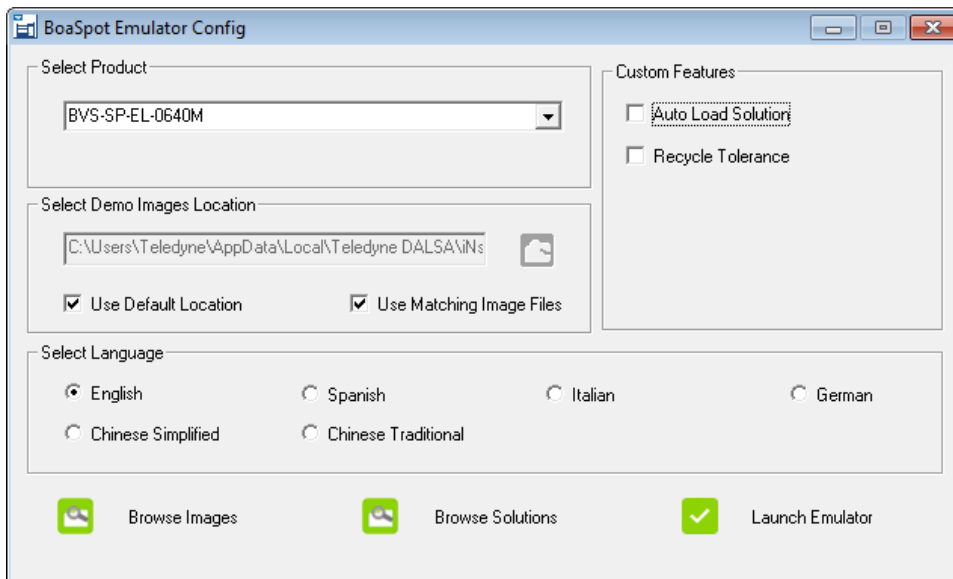

Use the BOA Spot Emulator Configurator the first time after installing or upgrading this software. When you click “Launch Emulator” a default configuration is saved. If you do not do this, some options may be incorrect. You may encounter features that do not exist in the BOA Spot.

The Emulator installation provides some 640x480 images to get started. These are selected when the “Use Default Location” box is checked. The application data directories are hidden under Windows 7 and 10 but they are accessible using the “Browse Images” or “Browse Solutions” buttons.

**Note:** If you select an image directory that also contains a solution00.bin file the Emulator uses that directory as the source for both images and solution files, not the default solutions directory. The “Browse Images” and “Browse Solutions” buttons will point to that directory. The Import Solution function still uses the default location.



## Data Collection

iCollect is a useful tool for some industries, such as Pharmaceutical, that require logging of system events. The iCollect program records activity or system events on networked BOA Spot (IDS & IDE only) cameras that have data collection enabled.

Types of system events collected are:

- ✓ Log on - successful and failed attempts
- ✓ Log off
- ✓ Save or load solution
- ✓ Stop or start inspecting

A copy of iCollect.exe is installed with the Emulator software. You can copy the exe file to a PC you wish to use for collecting event data. Any networked Windows PC will work as the iCollect data host. When started, the iCollect icon will appear in the system tray at the bottom of PC. Click on the icon to show or hide logged system events.

To enable sending of events on each connected BOA Spot IDS or IDE, go to the “User Admin” page on the iInspect Express GUI. Log in and check the Enable Event Logging box and enter the IP Address of the system collecting data (where iCollect.exe is running). For networked setups enter the IP address of the collection PC NIC. Click the “OK” button to complete the setup.

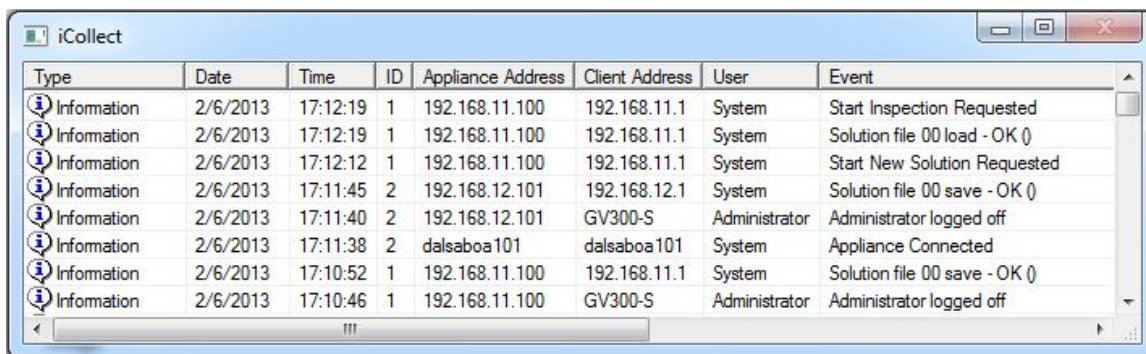

Type	Date	Time	ID	Appliance Address	Client Address	User	Event
Information	2/6/2013	17:12:19	1	192.168.11.100	192.168.11.1	System	Start Inspection Requested
Information	2/6/2013	17:12:19	1	192.168.11.100	192.168.11.1	System	Solution file 00 load - OK ()
Information	2/6/2013	17:12:12	1	192.168.11.100	192.168.11.1	System	Start New Solution Requested
Information	2/6/2013	17:11:45	2	192.168.12.101	192.168.12.1	System	Solution file 00 save - OK ()
Information	2/6/2013	17:11:40	2	192.168.12.101	GV300-S	Administrator	Administrator logged off
Information	2/6/2013	17:11:38	2	dalsaboa101	dalsaboa101	System	Appliance Connected
Information	2/6/2013	17:10:52	1	192.168.11.100	192.168.11.1	System	Solution file 00 save - OK ()
Information	2/6/2013	17:10:46	1	192.168.11.100	GV300-S	Administrator	Administrator logged off

The iCollect System Event Log

The iCollect log is stored as in a text file as “CSV” or Comma Separated Variables “iCollect.txt” in the same directory where iCollect.exe was run.

**Note:** If iCollect is enabled on BOA Spot IDS or IDE and not running on the connected PC, you will experience a delay at BOA Spot boot up as it attempts to find the collection server. Data will be stored on the BOA Spot if possible and transferred when the host PC reconnects.



# Troubleshooting Common Problems

## Problems Changing the IP Address

**Problem:** All fields are blank when I open **iDiscover** or **Nexus**. There are no BOA Spots listed. The PC and BOA Spot addresses are not shown in iDiscover.

**Reason 1:** This may indicate the PC and the BOA Spot have the same IP Address.

**Solution 1:** Close iDiscover. Use Windows Network Configuration to change the last field in the PC's IP Address.

**Reason 2:** WIFI or Wireless LAN adapters seem to interfere with the discovery. Wireless LAN often uses the same 192.168.x.x addresses range as default.

**Solution 2:** Disable or disconnect the Wireless LAN temporarily and change the BOA Spot to a different network neighborhood that is unrelated to your WIFI or your industrial network. One example is 10.1.x.x or 10.5.0.x. But these can also be popular with business networks. (**Tip:** 10.5.1.0 is another popular router address.)

**Reason 3: Routers** use Network Address Translation (NAT) and can interfere with finding the BOA Spot and changing address. **VPNs** can prevent finding the BOA Spot.

**Solution 3:** Connect the BOA Spot directly to the PC or Laptop to change its address. The correct address can be added in Nexus if it continues to be hidden by a router.

**Problem:** BOA Spot disappears in iDiscover after clicking "Apply". Does not reappear.

**Reason:** BOA Spot must be rebooted for the new address or name to take effect.

**Solution:** Close iDiscover. Cycle power to the BOA Spot. Wait for the boot to complete (about 20-30 seconds). Re-open iDiscover. BOA Spot should now appear.

**Problem:** Address does not change. BOA Spot still has the factory default address.

**Reason:** Possibly more than one BOA Spot on the network with the same (old or new) address. This can happen if multiple BOA Spots at the factory default are connected.

**Solution:** Disconnect the BOA Spot that does not change, verify that there are not other BOA Spots at that address. Connect one at a time to change the addresses.

**Network Ports & Security:** BOA Spot and iInspect require access to use network ports 80 and the range 5005 through 5025 plus any ports you configure for TCP communications.

**For more Troubleshooting** help please refer to the [BOA Troubleshooting Guide](#) available on the BOA or BOA Spot software download file or contact Teledyne Digital Imaging for a copy.

## Problems Connecting to BOA Spot

**Problem:** Cannot connect to the BOA Spot, the home page does not open.

**Reason:** iNspec for BOA Spot before release 2150 is not compatible with Microsoft Edge (W10 only).

**Solution:** Use Internet Explorer version 8 through 11 to connect to the BOA Spot home page. Starting with Release 2150 the BOA Spot is compatible with all browsers, but no longer launches iNspec. Use the Nexus application to open iNspec for BOA Spot.

**Problem:** Nexus detects the BOA Spot but status shows “unknown” problem.



**Reason 1:** The IP Addresses of the PC Network port and BOA Spot may not be compatible.

**Solution 1:** Click on the BOA Spot and then click the Edit button on the right to see the IP Address. Correct it if needed. Or use iDiscover.

**Reason 2:** WIFI or Wireless LAN adapters interfere with discovering BOA Spot. Many WIFI adapters also use the 192.168.x.x address range.

**Solution 2:** Temporarily disable or disconnect the WIFI adapter. Use iDiscover or Nexus to change the BOA Spot address to a completely different range; such as 10.1.x.x or 10.25.0.x. But these can also be popular with business networks. (Tip: 10.5.1.0 is another popular router address). Use a unique address range far away from all of these.

**Problem:** The iNspec for BOA Spot application window does not open.

**Reason 1:** A solution may be running in a very fast loop, repeating too fast to allow communication. This sometimes happens when experimenting with a minimal Solution.

**Solution 1:** Disconnect the trigger to pause the program or disable “Auto Load” and reboot the BOA Spot. If this works, increase the internal timer or add to your Solution.

**Reason 2:** Low on memory. The 256MB Program memory is used to cache acquired images, intermediate results, Match templates, and Solution files for quick switching.

**Solution 2:** Reboot the BOA Spot. A reboot clears cached Solutions, images, results.

**Reason 3:** A Solution may be running too slow. The trigger or timer is trying to acquire the next image before all instructions have completed. If you have added new Script instructions such as saving images, they may take too long.

**Solution 3:** If you have added new script instructions, try commenting them out temporarily to see if that is the source of the problem. Also, be aware that some tools can take much longer if the object they measure is not present (Match, Barcode, 2D-codes).

**Problem:** Failed to Connect. **Error 0x1007**. This message means the “Socket Connect” succeeded, but the message transfer which immediately follows, has failed.

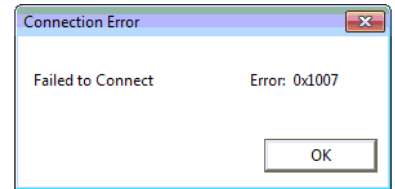

**Reason 1:** The NIC and BOA Spot addressing modes do not agree. One may be DHCP and the other LLA or fixed.

**Solution 1:** Configure the NIC and the BOA Spot for fixed IP Addressing.

**Reason 2:** This indicated the BOA Spot is “too busy” to respond. This indicated the BOA Spot is “too busy” to respond. The Solution may run too fast if you created a new Solution with few tools and a fast Internal Timer.

**Solution 2:** Disconnect or disable the trigger to pause the job. Disable “Auto Load” if possible. Reboot the BOA Spot. Increase the Internal Timer (slow down the BOA Spot).

**Reason 3:** The Solution may run too slow if you have added new instructions that take more time, such as saving images. The Internal timer or Trigger may be trying to acquire the next image before all instructions have completed.

**Solution 3:** If you have added new instructions try commenting them out.

**Problem:** After updating the firmware, I cannot reconnect to the BOA. Nexus gives me a message “Cannot download the files needed for this camera.”

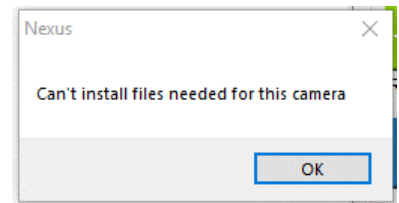

**Reason:** McAfee Virus scan is blocking files from installing or executing.

**Solution:** If possible, disable the virus scan software temporarily. Or open Virus Scan control center and unblock or enable files related to iInspect, iWorks, Nexus, etc.

**Problem:** After updating the firmware, I cannot reconnect to the BOA. iAssistant shows files highlighted in Red and Blue only. Clicking Clean is not deleting these files.

**Reason 1:** iAssistant is not running with Administrator privileges.

**Solution 1:** Go to the Windows Start menu and open the program group for Nexus BOA, iInspect BOA, or iInspect BOA Spot. Right-click on iAssistant, float over “More” and select “Run as administrator”. Click “Clean”. If Nexus has been downloaded from a BOA or Spot with the latest firmware, you can reload the iInspect files from iAssistant, by clicking “Re-install Client Files”.

**Reason 2:** Some files are still running in background and cannot be deleted.

**Solution 2:** Disconnect the BOA from the PC. Close all programs. Reboot the PC. Run iAssistant with Administrator privileges (See Solution 1 above). Click “Clean”. If Nexus has been downloaded from a BOA or Spot with the latest firmware, you can reinstall the latest files from iAssistant by clicking the “Re-install Client Files”.

**Problem:** After updating the firmware, I cannot reconnect to the BOA Spot.

**Reason:** The old support files may still be on your system if you did not “Clean” it.

**Solution:** Run iAssistant (page [50](#)). Click “Clean” to delete files from the previous version. Open Internet Explorer, open the Options menu, and click the “General” tab. Click on the Delete button and select all options to Delete Temporary Internet Files and Website pages” and click “Delete”. Reboot the system and connect to the BOA Spot. When you click on links on the home page new support files will be installed.

Also make sure you are not using the 64-bit version of Internet Explorer 8. Open Explorer and then open “About Internet Explorer”. “64-bit Edition” is explicitly shown. iDiscover and the Emulator Start Menu shortcuts point to the 32-bit Internet Explorer.

**Problem:** I cannot reconnect to the BOA Spot. I keep getting a message to run iAssistant and clean the system. Running iAssistant is not fixing the problem.

**Reason:** Either the BOA Spot or the PC may be “stuck” with a running process that does not quit when it should. Sometimes using sensors with different firmware versions (BOA, BOA2XA, BOA Spot) can cause this problem.

**Solution:** 1) Disable auto load (if possible) and reboot the BOA Spot. 2) Reboot the PC. 3) Run iAssistant again and click the “Clean” button. 4) Open Internet Explorer, open the Options menu and delete all history and pages in Cache. 5) Reboot the PC again. 6) Open iAssistant and click “Reinstall Client Files” New support files should be installed from the Nexus installation. 7) Open Nexus and reconnect to the BOA Spot.

**Problem:** Unreliable connection.

**Reason 1:** Internet Explorer Security settings, or Windows Firewall.

**Solution 1:** Refer to instructions on pages [33-35](#) on configuring the PC for BOA Spot. Disable the firewall. Use Nexus or the Emulator shortcuts to access the BOA Spot.

**Reason 2:** Low on memory. The 256MB Program memory is used to cache acquired images, intermediate results, Match templates, and Solution files for quick switching.

**Solution 2:** Reboot the BOA Spot. A reboot clears cached Solutions, images, results.

**Reason 3:** Running and looping too fast for communication.

**Solution 3:** Disconnect or disable the trigger signal to pause the program. Disable “Auto Load” if possible. Reboot the BOA Spot. If this works, try increasing the internal timer or adding tools.

**Reason 4:** Running too slow. If you have added instructions such as saving images, The trigger or timer interval may be occurring before all the instructions are completed.

**Solution 4:** Try commenting out new instructions to see if there is improvement.

## Problems Running BOA Spot Solutions

**Problem:** The Solution file will not load. Solution file not listed in Select Solution.

**Reason 1:** The Solution does not match the current BOA Spot (resolution or model).

**Solution 1:** Try loading the Solution in the Emulator and see what model is displayed. If you have trouble, try changing the resolution or model in the Emulator before loading.

**Reason 2:** If the Solution file will not load in the Emulator, either it does not match the current model or resolution, or the file may be corrupted.

**Solution 2:** If possible, use an earlier version of this Solution (if available) from before the loading problem began. Try creating a new Solution to see if it can be loaded.

**Problem:** BOA Spot always outputs a Fail pulse, even when the Monitor shows a Pass result.

**Reason:** The pulse offset may need to be increased, to allow for the inspection time.

**Solution:** Please refer to the formula on page [47](#), under “Pulse Setting”.

**Problem:** Program Switching is disabled.

**Reason:** Solution switching is disabled when you edit solution files, and when you export Solutions. Switching is re-enabled when you save or load a Solution.

**Solution:** Save the current solution or go to the Select Solution panel and load a solution. **Note:** Loading a Solution in the Run panel does not re-enable switching.

**Problem:** Display controls are disabled in the Run panel. Cannot change the display.

**Reason:** These controls are disabled when image logging is enabled.

**Solution:** Disable image logging to allow changing the display settings.

**Problem:** History Log disabled in the Run panel.

**Reason:** The History Log is disabled by default to save on memory.

**Solution:** History Log is enabled from the Connections panel.

**Problem:** The Locator does not work. The tools do not move in the Setup panel when I snap a new image.

**Reason:** The Locator works in Run mode, not in Setup mode.

**Solution:** Click on the Run button in the Navigation bar to see the Locator in operation.

## Problems Running the Emulator for BOA Spot

**Problem:** The Emulator does not display images. The image area only displays diagonal stripes (they may be colored also).

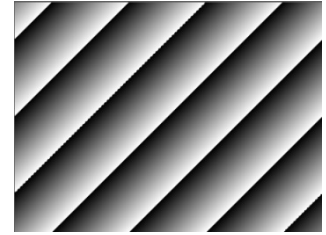

**Reason:** The images do not match the selected Resolution or format. The images included with the Emulator are 8-bit Mono 640 x 480 pixels. You may have selected a different image size and the “use matching image files” box is checked.

**Solution 1:** Close the Emulator and open the Configurator. Clear the box beside “use matching image files” to allow the sample images to display.

**Solution 2:** Close the Emulator and open the Configurator. Change your resolution to match the images (sample images are: Mono, 640 x 480).

**Solution 3:** Close the Emulator and open the Configurator. Clear the “Use Default Location” option and change the “Demo Images Location: to match the directory where your images are located.

**Problem:** The tools displayed do not match the BOA Spot model tool set.

**Reason:** You started the Emulator without first using the Emulator Configurator after installing. This error occurs after installing or upgrading the Emulator because there is no initialization file included in versions 2000 and later.

**Solution:** Close the Emulator. Open the Emulator Configurator (page). Select the BOA Spot model and resolution you need. Click “Launch Emulator”.

**Problem:** My Solution File does not load.

**Reason 1:** The Solution file does not match the Emulator configuration.

**Solution 1:** Close the Emulator. Open the Emulator Configurator. Select the BOA Spot model, color, and resolution to match your Solution file.

**Problem:** The Locator does not work. The tools do not move in the Setup panel when I snap a new image.

**Reason:** The Locator only works in Run mode, not in Setup mode.

**Solution:** Click on the Run button in the Navigation bar to see the Locator in operation. Return to the Tools Setup panel to correct any issues with the Locator, then add tools.

**For more Troubleshooting** help please refer to the [BOA Troubleshooting Guide](#) available on the BOA or BOA Spot software download file or contact Teledyne Digital Imaging for a copy.